

THE EAGLE HM INDUSTRIAL

A high-mounting version of BEA's proven Eagle technology for industrial applications.

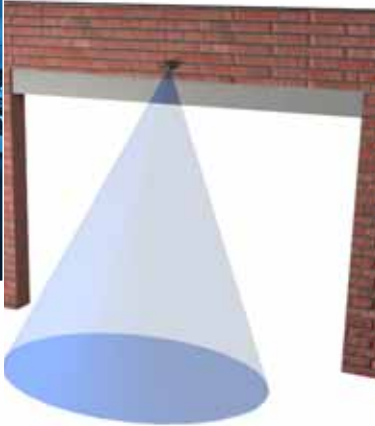

**Quality
Intelligence
Precision**

Optimal Technology for Activation

The Eagle HM utilizes K-band microwave technology, which is unaffected by color or changes in temperature, and can detect movement at rates as slow as 2.2 inches/second.

Safe and Efficient Solution

3-Mode directional sensing feature for; motion towards the door (Uni-directional), motion towards or away from the door (Bi-directional), or a combination of both (Motion Tracking Feature).

Easy and Adaptable for Industrial Doors

With effective detection up to a 17ft. mounting height, the sensor can be set up with the BEA remote control, thus eliminating the need for ladders and minimizing down time.

Adjustable To Your Needs

The Eagle HM can accommodate any industrial door or gate application with adjustable relay hold times, normally open or normally closed contacts.

WWW.BEASENSORS.COM

A HALMA COMPANY



AAADM American Association of Automatic Door Manufacturers



THE EAGLE HM INDUSTRIAL

A high-mounting version of BEA's proven Eagle technology for industrial applications.

DIMENSIONAL DRAWINGS

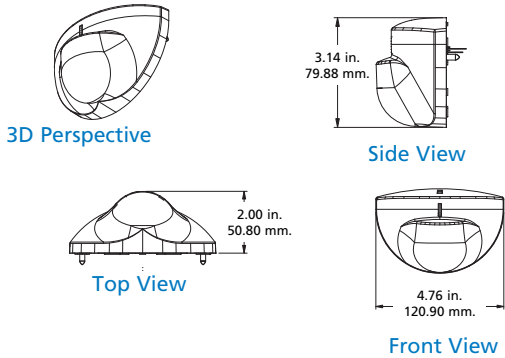

APPLICATION

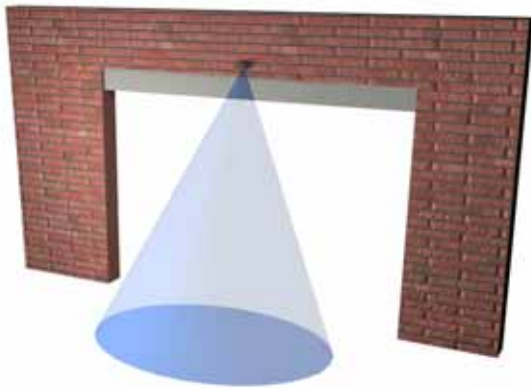

■ Microwave detection pattern for industrial doors

ACCESSORIES



ECA
Accessory for mounting in false ceiling



HD Bracket
Heavy-Duty Extension Bracket extends up to 3 ft. from the wall



EBA
Another mounting possibility



ERA
Rain cover accessory

TECHNICAL SPECS

Frequency
24.125 GHz

Supply voltage
12 to 24 VAC \pm 10%
12 to 24 VDC -10% / +30%

Mounting height
17 ft.

Tilt angle
0° to 90° vertical
-30° to +30° lateral

Detection area
13.1 ft. x 8.2 ft.

Minimum detection speed
2in/sec. (measured in axis)

Power consumption
< 2 W

Standard output relay
Max contact voltage
60 VDC / 125 VAC

Max contact current
1 A (resistive)

Max switching power
30W (DC) / 60VA (AC)

Hold time
0.5 sec. to 9 sec. (adjustable)

Temperature range
-4°F to 131°F
-20°C to 55°C

Dimensions
4.75 in. (W) x 3.15 in. (H)
x 2.0 in. (D)

Weight
0.5lbs

Material
ABS

Housing color
Black. Can be painted with non-metallic paint

Cable length
30 ft.

COMPONENTS



- 1 Manual Set-up Buttons
- 2 Terminal Block
- 3 Wire Passage Hole
- 4 Planar Antenna
- 5 Lateral Adj. For Antenna
- 6 Universal Remote Control

RELATED PRODUCTS



24VAC Transformer Bodymount IRIS I

Contact Information

BEA Inc.
RIDC Park West
100 Enterprise Drive
Pittsburgh, PA 15275
PHONE: 1 412.249.4100
FAX: 1 888.523.2462
TOLL FREE: 1 800.523.2462

BEA West
190 E. Arrow Hwy. Suite A
San Dimas, CA 91773
FAX: 1 909.596.5411
TOLL FREE: 1 877.232.9378



A HALMA COMPANY