



1 Description & Installation

BEA Escutcheon is designed to provide an attractive mounting box for 6" round pushplates. It is made of durable 304 stainless steel to match BEA's 6" round pushplate. It can be surface-mounted directly to a wall, or attached to a single-gang, double-gang or 4X4 electrical box.

1. Fasten Escutcheon to wall surface.
2. Route wiring to pushplate switch through the appropriate hole (F).
3. Attach pushplate to Escutcheon.

KEY	QTY	SCREW TYPE	USE
A	4	 #12 X 1 7/16" Plastic Anchor	Wall
B	4	6-32 X 1/2" Machine Screw	Single-Gang
C			Double-Gang
D	4	 8-32 X 3/4" Machine Screw	4 X 4 Box
E	*	 6-32 X 1" Socket Screw	Pushplate
F	N/A	Pushplate wiring (power cable) access	

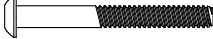
* - 2 screws are included with pushplate.

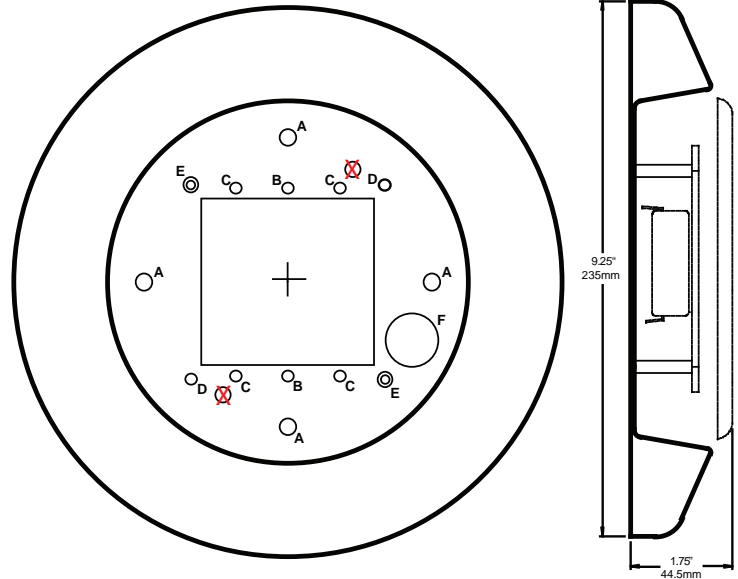

2 Precautions



- Shut off all power going to header before attempting any wiring procedures.
- Maintain a clean & safe environment when working in public areas.
- Constantly be aware of pedestrian traffic around the door area.
- Always stop pedestrian traffic through the doorway when performing tests that may result in unexpected reactions by the door.
- ESD electrostatic discharge: Circuit boards are vulnerable to damage by electrostatic discharge. Before handling any board ensure you dissipate your body's charge.
- Always check placement of all wiring before powering up to insure that moving door parts will not catch any wires and cause damage to equipment.
- Ensure compliance with all applicable safety standards (i.e. ANSI A156.10 / A156.19) upon completion of installation.
- DO NOT attempt any internal repair of the sensor. All repairs and/or component replacements must be performed by BEA, Inc. Unauthorized disassembly or repair:
 1. May jeopardize personal safety and may expose one to the risk of electrical shock.
 2. May adversely affect the safe and reliable performance of the product will result in a voided product warranty.

3 Company Contact



Do not leave problems unresolved. If a satisfactory solution cannot be achieved after troubleshooting a problem, please call BEA, Inc. If you must wait for the following workday to call BEA, leave the door inoperable until satisfactory repairs can be made. Never sacrifice the safe operation of the automatic door or gate for an incomplete solution.

The following numbers can be called 24 hours a day, 7 days a week. For more information, visit www.beasensors.com.



US and Canada: 1-866-249-7937
Canada: 1-866-836-1863
Northeast: 1-866-836-1863

Southeast: 1-800-407-4545
Midwest: 1-888-308-8843
West: 1-888-419-2564

1 Description & Installation

BEA Escutcheon is designed to provide an attractive mounting box for 4.5" round pushplates. It is made of durable 304 stainless steel to match BEA's 4.5" round pushplate. It can be surface-mounted directly to a wall, or attached to a single-gang or double-gang box.

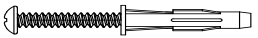
1. Fasten Escutcheon to wall surface.
2. Route wiring to pushplate switch through the large square hole.
3. Attach pushplate to Escutcheon.

KEY	QTY	SCREW TYPE	USE
A	4	 #12 X 1 7/16" Plastic Anchor	Wall
B	4	 6-32 X 1/2" Machine Screw	Single-Gang
C			Double-Gang
D	2	 6-32 X 1 1/4" Socket Screw	Pushplate

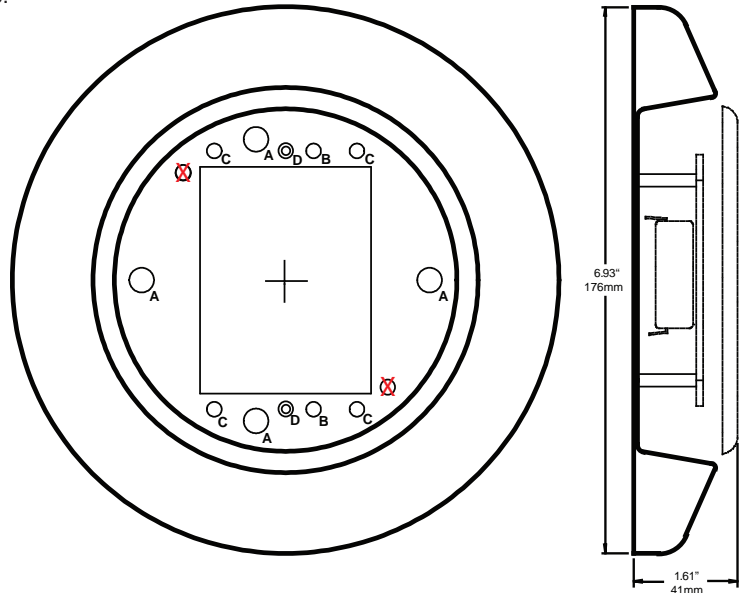

NOTE: Socket screws are inserted into appropriate holes / posts for attaching the pushplate. The other two holes / posts are used to support the pushplate.

2 Precautions



- Shut off all power going to header before attempting any wiring procedures.
- Maintain a clean & safe environment when working in public areas.
- Constantly be aware of pedestrian traffic around the door area.
- Always stop pedestrian traffic through the doorway when performing tests that may result in unexpected reactions by the door.
- ESD electrostatic discharge: Circuit boards are vulnerable to damage by electrostatic discharge. Before handling any board ensure you dissipate your body's charge.
- Always check placement of all wiring before powering up to insure that moving door parts will not catch any wires and cause damage to equipment.
- Ensure compliance with all applicable safety standards (i.e. ANSI A156.10 / A156.19) upon completion of installation.
- DO NOT attempt any internal repair of the sensor. All repairs and/or component replacements must be performed by BEA, Inc. Unauthorized disassembly or repair:
 1. May jeopardize personal safety and may expose one to the risk of electrical shock.
 2. May adversely affect the safe and reliable performance of the product will result in a voided product warranty.

3 Company Contact



Do not leave problems unresolved. If a satisfactory solution cannot be achieved after troubleshooting a problem, please call BEA, Inc. If you must wait for the following workday to call BEA, leave the door inoperable until satisfactory repairs can be made. Never sacrifice the safe operation of the automatic door or gate for an incomplete solution.

The following numbers can be called 24 hours a day, 7 days a week. For more information, visit www.beasensors.com.

US and Canada: 1-866-249-7937
Canada: 1-866-836-1863
Northeast: 1-866-836-1863

Southeast: 1-800-407-4545
Midwest: 1-888-308-8843
West: 1-888-419-2564