

FALCON EX USER'S GUIDE

EXPLOSION-PROOF HOUSING AND MOTION SENSOR FOR INDUSTRIAL DOORS

- **FALCON EX:** for high mounting
- **FALCON EX-XL:** for wide angle

TECHNICAL SPECIFICATIONS

Technology:

Microprocessed microwave motion detector

Transmitter frequency: 24.125 GHz

Transmitter radiated power: <20 dBm EIRP

Transmitter power density: < 5 mW/cm²

Mounting height:

FALCON EX: from 11.5 to 23'

FALCON EX-XL: from 6.5 to 11.5'

Tilt adjustment angle: -90° to +30° in elevation

Detection zone (typical)

Narrow pattern (FALCON EX):

13' (W) x 16' (D) for a mounting height of 16'

Wide pattern (FALCON EX-XL):

13' (W) x 6.5' (D) for a mounting height of 8.2'

Minimum detection speed:

2.2 in/s (measured in the sensor axis)

Supply voltage:

12 to 24VAC +/- 10%

12 to 24VDC +30% / -10%

Mains frequency: 50 to 60 Hz

Power consumption: < 2W

Output relay: free of potential changeover contact

Max contact voltage: 42VAC/VDC

Max contact current: 1A (resistive)

Max switching power: 30W (DC) / 60 VA (AC)

Hold time: 0.5s to 9s (adjustable)

Manual adjustment:

- orientation of sensing field (mechanically)
- multiple functions (by push buttons).

Remote control adjustments:

- Sensitivity.
- Hold time.
- Detection mode.
- Pedestrian and parallel traffic rejection mode.
- Relay configuration.

Temperature range: -22°F to 122°F (-30°C to +60°C)

Housing Certification:

UL Class I, Groups B,C,D

UL Class II, Groups E,F,G

UL Class III

CENELEC: EExd IIC, IP66

NEMA 4x, 7BCD, 9EFG

Product conformity:

R&TTE 1999/5/EC

EMC 89/336/EEC

Dimensions (Housing and bracket):

9 in. (D) x 7 1/2 in. (W) x 5 1/2 in. (H)

(229 mm (D) x 190 mm (W) x 140 mm (H))

Weight: 10 lbs (4.5 kg)

Housing Material: Copper-free aluminum

Bracket Material: Aluminum

Cable length: 33 ft (10 m)

Cable diameter: 1/4" (6.5 mm) (maximum)

DESCRIPTION OF THE SENSOR

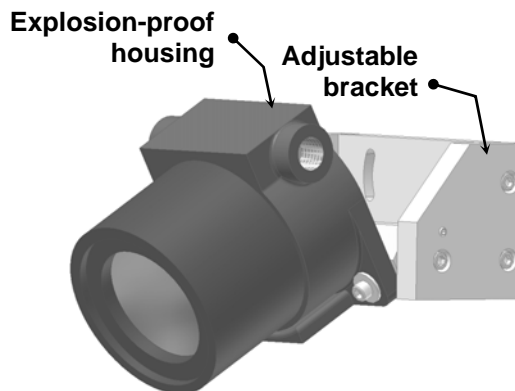

Assembled Sensor

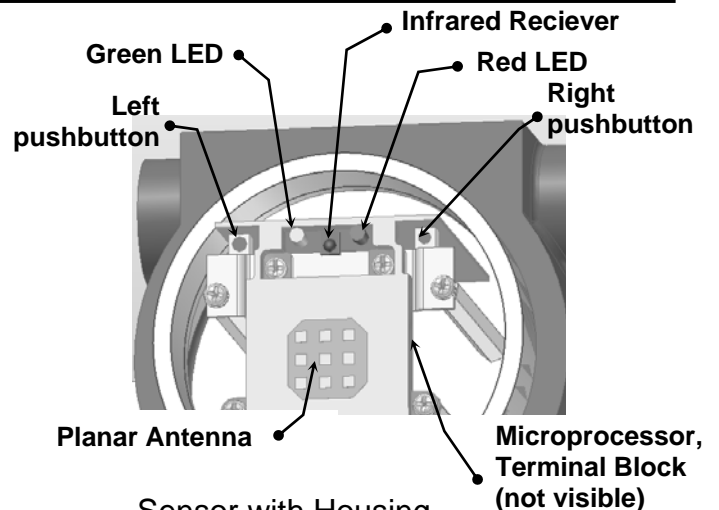

Sensor with Housing
Cover Removed

INSTALLATION TIPS

- The sensor must be firmly fastened in order not to vibrate.
- The sensor must not be placed directly behind a panel or any kind of material.
- The sensor must not have any object likely to move or vibrate in its sensing field.
- The sensor must not have any fluorescent lighting in its sensing field.

WIRING



Red	Black	White	Green	Yellow: US Wire Colors
12-24	VAC/VDC	COM	NO	NC
Brown	Green	White	Yellow	Grey: European Wire Colors

- The cable will arrive wired to the connector. Simply route the cable through appropriate conduit and wire it to the door control.

OPENING AND CLOSING THE HOUSING

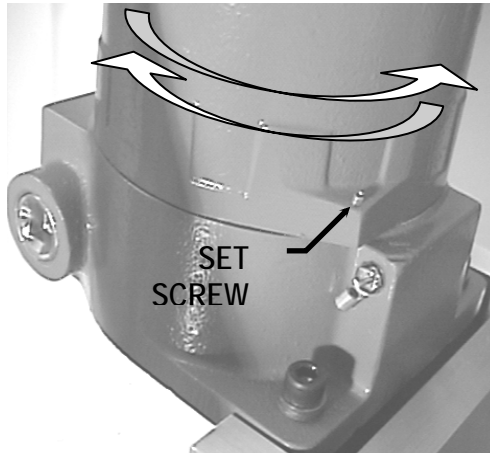

NOTE: Normally, opening the sensor is not necessary, unless access to the manual pushbuttons is required.

- Using a hex key loosen or tighten the setscrew located on the side of the housing.
- Unscrew/ Screw the housing cover.

SENSOR MOUNTING/ ADJUSTMENT

1. Bolt the bracket securely to the wall or other rigid surface.
2. Make sure that the two hex head bolts are loose so that the sensor can rotate freely.
3. Rotate the sensor to the appropriate angle for the application. When the bracket rotates, it will click. Every click represents a 7 1/2° angle adjustment.
4. Lock the angle adjustment by tightening the two hex bolts.
5. Horizontal angle adjustments can be made by loosening the mounting bolts on the base and twisting to the desired angle.

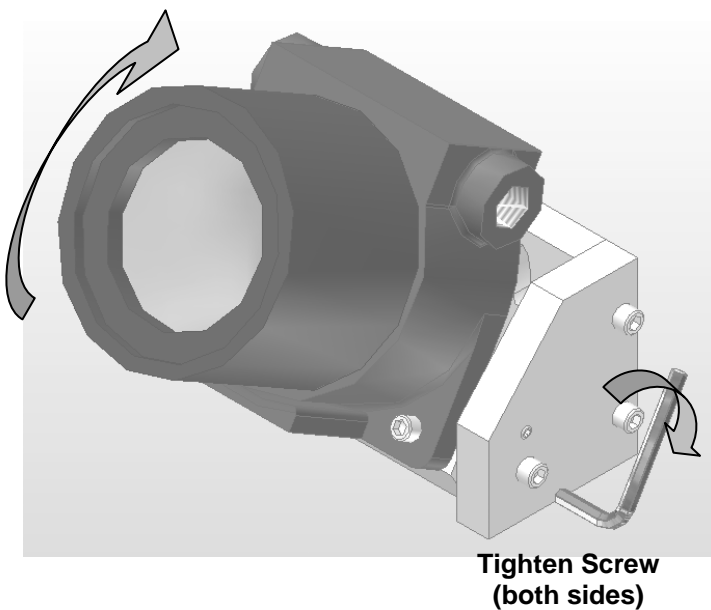

Maximum angle (-30° above horizon)

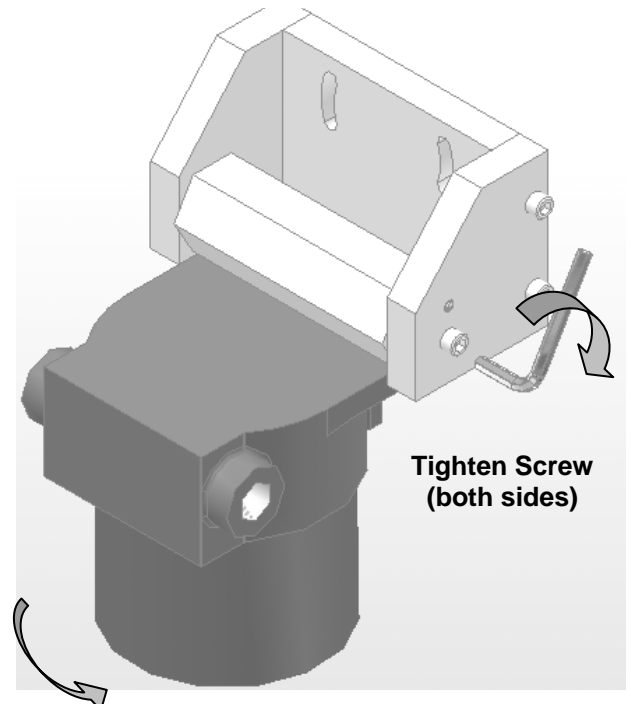

Minimum angle (90° below horizon)

SETTING
THE SENSING
FIELD
DIMENSIONS

FALCON EX (Mounting height: 16.5 feet)

The sensing fields here on the right correspond to the following adjustments:

- tilt angle: 15°, 30°, 45°
- sensitivity: 9.

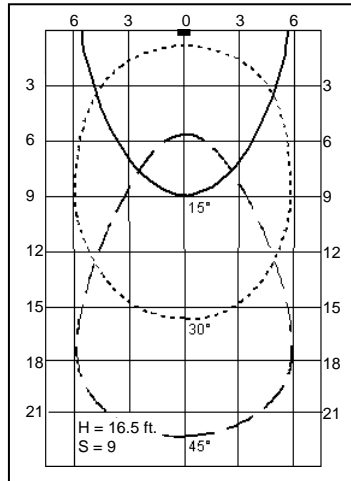

The sensing fields here on the right correspond to the following adjustments:

- tilt angle: 30°
- sensitivity: 9, 6, or 3

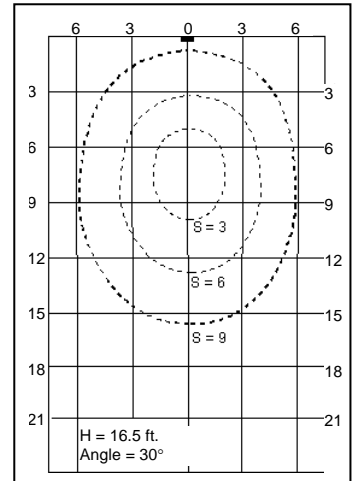

FALCON EX (Mounting height: 11.5 feet)

The sensing fields here on the right correspond to the following adjustments:

- tilt angle: 15°, 30°, 45°
- sensitivity: 9.

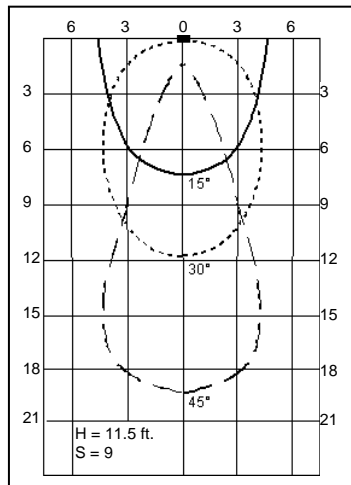

The sensing fields here on the right correspond to the following adjustments:

- tilt angle: 30°
- sensitivity: 9, 6, or 3

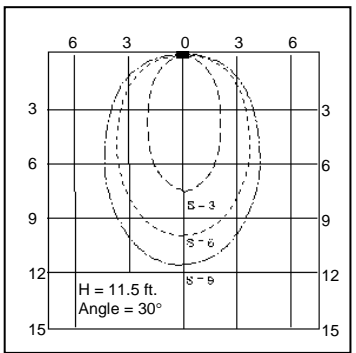

FALCON EX-XL (Mounting height: 8 feet)

The sensing fields here on the right correspond to the following adjustments:

- tilt angle: 15°, 30°, 45°
- sensitivity: 9.

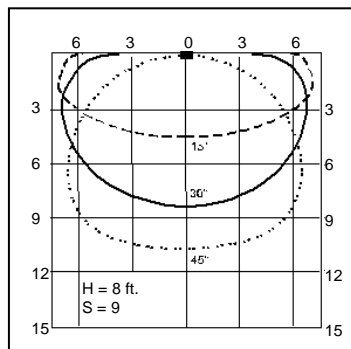

The sensing fields here on the right correspond to the following adjustments:

- tilt angle: 30°
- sensitivity: 9, 6, or 3

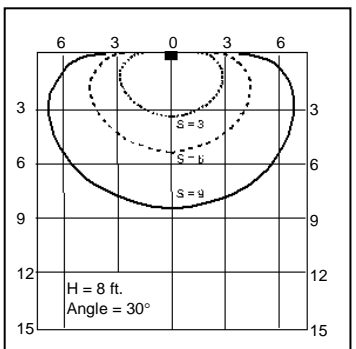

LED SIGNAL

- When the power is turned ON, the red and green LEDs flash for few seconds.
- During a detection the red LED lights illuminates.
- During configuration, the red LED flashes a number of times corresponding to the parameter being changed (see next table). The green LED flashes a number corresponding to its setting.

1. DESCRIPTION OF THE INFRARED REMOTE CONTROL



- Open the battery compartment at the back of the remote control.
- Insert two AAA batteries supplied with the remote control.
- Close the battery compartment.

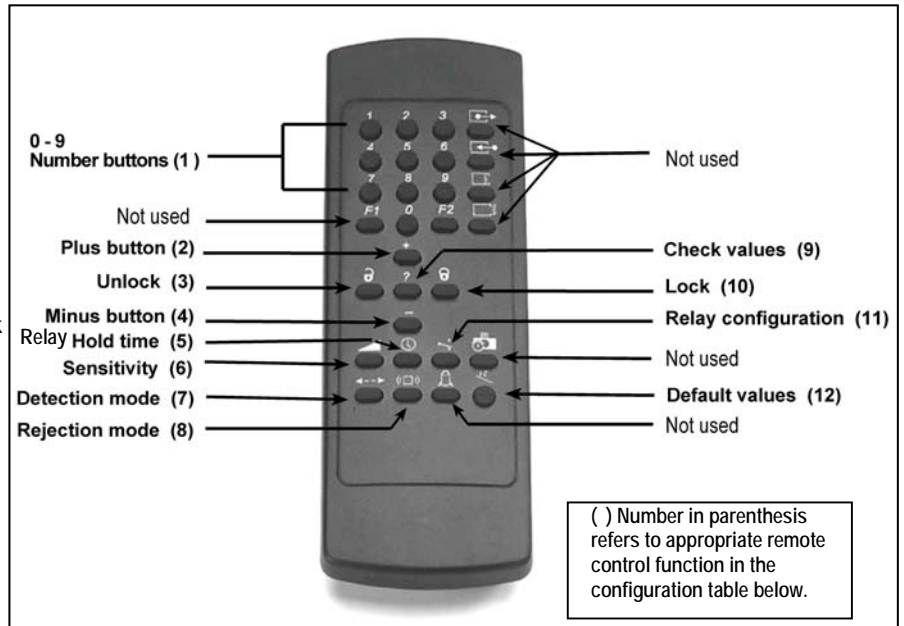

















Remark: For optimum results point the remote control at the sensor before pressing its buttons.

2. CONFIGURATION OF THE SENSOR















Each setting change using the infrared remote control must start with an unlocking and end with a locking of the sensor. It is important to point out that any parameters changed using the remote control supersede any previous setting.





The table below lists all the parameters, which can be adjusted with the remote control as well as the operations, required to adjust them.

















































PARAMETER KEY	USER'S ACTIONS	FACTORY SETTING	LED SIGNAL
UNLOCK 	<p>Press the UNLOCK key (3). Enter your four-digit access code using NUMBER keys 0-9 (1).</p> <p>During the first sensor adjustment, or if the access code is reset to the "0000" value (factory setting) during the first minute after the power-on (see below), press only the UNLOCK key (3) (no code required).</p> <p><i>UNLOCK with code</i>      <i>UNLOCK without code</i> </p>	0000	<p>The red LED flashes quickly waiting for the access code.</p> <p>After entering the correct code or if no code is required, the red LED flashes slowly to indicate that the unlock is successful and the adjustment session has begun.</p> <p>Note:  = Adjustment session ON</p>
LOCK 	<p>When all the parameters have been set, press the LOCK key (10).</p> <p>If you wish to enter a new access code, use NUMBER keys 0-9 (1) to enter the new four-figure code within 20 seconds.</p> <p>If no access code is entered or if you want to keep the current access code, press the LOCK key (10) once more.</p> <p>If no remote control key is pressed within 1 minute, the adjustment session is automatically locked.</p> <p>Pressing the LOCK key (10) twice within the first minute after powering-up the sensor automatically resets the access code to 0000.</p> <p><i>LOCK with code change</i>      <i>LOCK without code or Code change</i>  </p>	0000	<p>The red LED stops flashing to return to its normal function.</p>

During an adjustment session each parameter may be checked or changed at any time in the following way:

PARAMETER KEY	USER'S ACTIONS
CHECK VALUES 	Press the key (5,6,7,8,11) corresponding to the parameter to be checked and then press the CHECK VALUES key (9) . Count the number of times the green LED flashes. That number corresponds to the value of the checked parameter. No green LED flash corresponds to the value 0. Repeat this operation to check the value of the other parameters if required. Example: SENSITIVITY key (6) – 7 flashes of the green LED: the sensitivity is set at the value 7. CHECK VALUES:   
PLUS 	Press the key (5 or 6) corresponding to the hold time or sensitivity parameter to be modified and then press the PLUS key (2) to increase the value by 1 unit. PLUS:   
MINUS 	Press the key (5 or 6) corresponding to the hold time or sensitivity parameter to be modified. and then press the MINUS key (4) to reduce the value by 1 unit. MINUS:   

During a sensor adjustment session all the parameters may be reset to their factory values in the following way:

PARAMETER KEY	USER'S ACTIONS
DEFAULT VALUES 	Press the DEFAULT VALUES key (12) , then press the NUMBER key 1 . All the parameters are reset to the factory values (see below). DEFAULTS VALUES:   

PARAMETER KEY	USER'S ACTIONS	FACTORY SETTING	LED SIGNAL																					
SENSITIVITY 	Press the SENSITIVITY key (6) . Use the NUMBER keys 0-9 (1) to enter the sensitivity required (or adjust this sensitivity using the PLUS (2) or MINUS (4) keys as explained above) SENSITIVITY:   	7	The red LED flashes quickly waiting for the value. Once this has been entered, it flashes slowly again.																					
HOLD TIME 	Press the RELAY HOLD TIME key (5) . Use the NUMBER keys 0-9 (1) to enter the required hold time (0.5 s to 9 s) (or adjust this parameter using the PLUS (2) or MINUS (4) keys as explained above). HOLD TIME:   	0.5 s	The red LED flashes quickly waiting for the value. Once this has been entered, it flashes slowly again.																					
RELAY CONFIGURATION 	Press the RELAY CONFIGURATION key (11) . Use the NUMBER keys 1-4 (1) to select the required relay configuration: <table border="1" data-bbox="347 1592 991 1823"> <thead> <tr> <th></th> <th>Active</th> <th>Passive</th> <th>+ 1</th> <th>+ 2</th> <th>+ 3</th> <th>+ 4</th> </tr> </thead> <tbody> <tr> <td>Detection</td> <td></td> <td></td> <td></td> <td></td> <td></td> <td></td> </tr> <tr> <td>No Detection</td> <td></td> <td></td> <td></td> <td></td> <td></td> <td></td> </tr> </tbody> </table> <p>[The number in parenthesis () represents the terminal number on the terminal strip.]</p>		Active	Passive	+ 1	+ 2	+ 3	+ 4	Detection							No Detection							1 (Active Output)	The red LED flashes quickly waiting for the value. Once this has been entered, it flashes slowly again.
	Active	Passive	+ 1	+ 2	+ 3	+ 4																		
Detection																								
No Detection																								
DETECTION MODE 	Press the DETECTION MODE key (7) . Use the NUMBER keys 1-3 (1) to select the required mode: key 1: bi-directional key 2: unidirectional approach key 3: unidirectional depart (detection as the object moves away) Detection mode:   	2 (Unidirectional Approach)	The red LED flashes quickly waiting for the value. Once this has been entered, it flashes slowly again.																					

<p>REJECTION MODE</p> 	<p>Press the REJECTION MODE key (8). Immunity is used to avoid detection due to environmental interferences (vibrations, rains, etc). “Pedestrian/parallel traffic rejection” provides both rejection of pedestrian and rejection of any parallel traffic at the same time.</p> <p>Use the NUMBER keys 1- 5 (1) to enter the required rejection mode: key 1 : detection of all kind of objects in motion key 2 : detection of all kind of objects in motion + interference immunity key 3 : Low “Pedestrian/parallel traffic” rejection + interference immunity key 4 : Mid “Pedestrian/parallel traffic” rejection + interference immunity key 5 : High “Pedestrian/parallel traffic” rejection + interference immunity key 6 : Extra High “Pedestrian/parallel traffic” rejection + interference immunity</p> <p>The ability to discriminate between a pedestrian and different types of vehicles depends mainly on the mounting height and the sensor’s tilt angle. Be careful that the rejection function increases the response time of the sensor.</p> <p>Recommended rejection levels. Increase or decrease level as necessary to obtain the required rejection.</p> <table border="1" data-bbox="466 862 874 1220"> <thead> <tr> <th colspan="2" rowspan="2">Recommended key</th> <th colspan="3">Tilt angle</th> </tr> <tr> <th>15°</th> <th>30°</th> <th>45°</th> </tr> </thead> <tbody> <tr> <td rowspan="3">Mounting height</td> <td>FALCON</td> <td>23 ft</td> <td>3</td> <td>4</td> <td>4</td> </tr> <tr> <td></td> <td>16.5 ft</td> <td>3</td> <td>4</td> <td>4</td> </tr> <tr> <td></td> <td>11.5 ft</td> <td>4</td> <td>4</td> <td>5</td> </tr> <tr> <td rowspan="2">FALCON XL</td> <td></td> <td>10 ft</td> <td>3</td> <td>4</td> <td>4</td> </tr> <tr> <td></td> <td>7.5 ft</td> <td>4</td> <td>4</td> <td>5</td> </tr> </tbody> </table>	Recommended key		Tilt angle			15°	30°	45°	Mounting height	FALCON	23 ft	3	4	4		16.5 ft	3	4	4		11.5 ft	4	4	5	FALCON XL		10 ft	3	4	4		7.5 ft	4	4	5	<p>1 (No rejection and no immunity)</p>	<p>The red LED flashes quickly waiting for the value. Once this has been entered, it flashes slowly again.</p>
Recommended key				Tilt angle																																		
		15°	30°	45°																																		
Mounting height	FALCON	23 ft	3	4	4																																	
		16.5 ft	3	4	4																																	
		11.5 ft	4	4	5																																	
FALCON XL		10 ft	3	4	4																																	
		7.5 ft	4	4	5																																	

FUNCTION PROGRAMMING WITH PUSH BUTTONS

Without remote control all of the parameters can be set using the 2 push buttons.
Note: These two buttons are accessible by opening the sensor housing as shown on page 2.

- To adjust the sensor using the buttons:
Press and hold either push button for 2 seconds (until the LEDs flash) and then release the button.
- To end adjusting the sensor using the buttons:
Press and hold either push button for 2 seconds (until the LEDs stop flashing) and then release the button;
Note: if no button is pressed within 20 seconds the adjustment session is automatically ended.
- To reset all the parameters to the factory values:
Press and hold both push buttons simultaneously until the two LEDs switch on for 1 second.
During the manual adjustment session the red and green LEDs flash successively and continuously.
- The flashing number of the **red LED** provides the **number of the displayed parameter** (see table below);
- The flashing number of the **green LED** provides the **value of the displayed parameter**;
Note: no green LED flashing indicates the zero value.

During the manual adjustment session:

- Each press on the **right button increases the number of the displayed parameter** by one unit;
- Each press on the **left button increases the value of the displayed parameter** by one unit.

Note: When the maximum value of the parameter is reached, the parameter will then “roll over” to its minimum value.

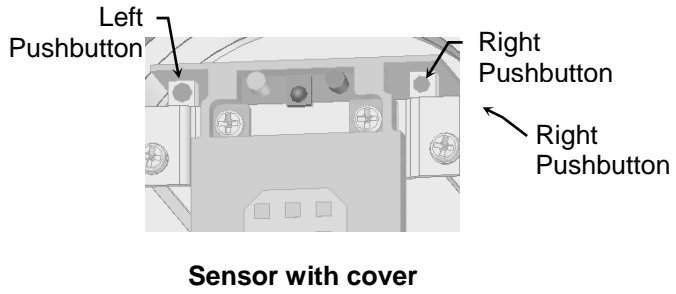

Parameter Number	Parameter	Values	Factory setting
1	Sensitivity	0 - 9	7
2	Hold time	0 - 9	0
3	Relay configuration	1 - 4	1
4	Detection mode	1 - 3	2
5	Pedestrian rejection mode	1 - 5	1

Example: to change the **Sensitivity** from 7 to 9 and the **Rejection mode** from “detection of all kind of targets in motion” to High “Pedestrian/parallel traffic” rejection.

- Press any button for 2 seconds to enter the adjustment session and then release it.
- The red LED flashes once (parameter 1 = sensitivity) and the green LED flashes 7 times (sensitivity=7).
- Press the left button twice to increase the sensitivity from 7 to 9.
- The red LED still flashes once (parameter 1 = sensitivity) but the green LED flashes 9 times now (sensitivity=9).
- Now press the right button 4 times to move to function 5 (rejection mode) ;
- The red LED flashes 5 times (parameter 5 = rejection mode) and the green LED flashes once (“detection of all kind of targets in motion”) ;
- Press the left button 4 times to set the parameter to High “Pedestrian/parallel traffic” rejection.
- The red LED still flashes 5 times (parameter 5 = rejection mode) but the green LED flashes 5 times now (High “Pedestrian/parallel traffic” rejection).
- Press any button during 2 seconds to end the adjustment session and then release it.

TROUBLE-SHOOTING

SYMPTOM	PROBABLE CAUSE	CORRECTIVE ACTION
The door will not open and the red LED does not light up.	The sensor power is off.	Check power supply. Check the supply voltage.
The door opens and closes constantly.	The sensor "sees" the door moving.	Increase the tilt angle and/or reduce the sensitivity.
	When closing, the door creates vibrations picked up by the sensor.	Ensure that the sensor is correctly attached. If the rejection mode is set at level 1, set this parameter to level 2. Reduce the sensitivity. Switch to unidirectional mode.
The door opens and closes after a given time for no apparent reason.	The sensor is picking up unintended traffic motion.	Reduce the sensitivity. Reduce the tilt angle.
The sensor is not capable of activation near the door.	The tilt angle is too large.	Reduce the tilt angle.
The sensor does not respond to the remote control.	The batteries are weak.	Check the batteries insertion. Change the batteries.
	The access code has been changed.	<ul style="list-style-type: none"> • Press both push buttons on the sensor simultaneously to reset all the parameters to the factory values. • Or switch off the power supply. Within the first minute after the power on, change the access code.



Do not leave problems unresolved. If a satisfactory solution cannot be achieved after troubleshooting a problem, please call BEA, Inc. If you must wait for the following workday to call BEA, leave the door inoperable until satisfactory repairs can be made. Never sacrifice safe operations for an incomplete solution.

The following numbers can be called 24 / 7. For more information, visit www.beasensors.com.

8 am - 5 pm EST: 1-800-243-2462		8 am - 5 pm PST: 1- 877-232-9378	
After Normal Business Hours			
West / Mexico 1-888-419-2564	Central 1-800-407-4545	AK, MI, WI, TX, Canada 1-866-836-1863	East 1-866-249-7937