

LOCKOUT MODULE FOR DC/PWM POWERED SWINGING or BI-FOLDING DOORS

1 Description

The LO Linx (10LOLINX) is a programmable lockout module used for any automatic swing door and bi-folding applications with a DC/PWM motor. The module provides sensor plug-in connectors, and easy 2-button digital programming with a user-friendly display. The LO-Linx product line is identified by a red translucent housing.



2 Specifications

DESCRIPTION	SPECIFICATION	COMPONENT INPUTS	COMPONENT OUTPUTS
Supply voltage	12 to 24 VAC/VDC: +/- 10%	(2) Eagle Motion Sensors	(1) Door Control
Power frequency	50/60 Hz	(1) Bodyguard Sensor *	
Power consumption	80mA max. (No load applied)	(2) Pair of Superscan Sensors	
Temperature range	-4°F to +131°F (-4°C to +131°C)	(2) Stall Inhibit Terminals	
Dimensions	5.2' (133mm) W x 2.2' (55mm) D x 1' (25mm) H	(1) Auxiliary: Push Plates, RF, etc.	
Housing material	ABS – Red Translucent	(1) SBK 30 Photo Beam pair	
Relay specification	Max. switching voltage: 125 VAC, 60VDC Max. switching current: 1A Max. switching power: 62.5VA, 30W	(1) Motor (1) On/Off/Hold Switch	
		* Use Y-Harness for 2 nd Bodyguard (Dual Egress).	
		NOTE: Listed components will only work with a DC motor and PWM and will not work with an AC motor.	

3 Precautions



- Shut off all power before attempting any wiring procedures.
- Maintain a clean & safe environment when working in public areas.
- Constantly be aware of pedestrian traffic around the door area.
- Always stop pedestrian traffic through the doorway when performing tests that may result in unexpected reactions by the door.
- ESD electrostatic discharge: Circuit boards are vulnerable to damage by electrostatic discharge. Before handling any board ensure you dissipate your body's charge.
- Always check placement of all wiring before powering up to insure that moving door parts will not catch any wires and cause damage to equipment.
- Ensure compliance with all applicable safety standards (i.e. ANSI A156.10) upon completion of installation.
- DO NOT attempt any internal repair of the sensor. All repairs and/or component replacements must be performed by BEA, Inc. Unauthorized disassembly or repair:
 1. May jeopardize personal safety and may expose one to the risk of electrical shock.
 2. May adversely affect the safe and reliable performance of the product resulting in a voided warranty.

4 Pre Installation Check

1. When preparing to wire multiple devices together for a 'system' configuration, it is best to ensure the correct operation of each device independently before starting to help reduce troubleshooting time later in the event of a discrepancy.
2. Prior to installing any equipment, ensure the correct line voltage and stability. When applying equipment on a new installation utilizing new electrical supply circuits, always ensure that correct line voltage exists and is stable. Remember to shut the power back off after this is checked and before performing any wiring to the system.

5 Installation

1 Introduction

Steps for Installing the LO Linx Module:

- Step 1:** Introduction
- Step 2:** Install LO Linx Module
- Step 3:** Install On/Off/Hold Switch
- Step 4:** Install Bodyguard
- Step 5:** Install Motor Harness Cable
- Step 6:** Install Five Wire Harness to Door Control
- Step 7:** Connect Power Harness
- Step 8:** Bodyguard III Setup
- Step 9:** Un Plug 2-Pin Power Connector

Steps for Installing the LO Linx Module (Continued):

- Step 10:** Activate LO Linx
- Step 11:** Check Door Polarity
- Step 12:** Install Activation Device Eagle
- Step 13:** Install Push Plates
- Step 14:** Knowing Act Installation and Setup
- Step 15:** InstallSuperscan
- Step 16:** Check Function Stall Logic
- Step 17:** Install Photo Beam SBK-30
- Step 18:** Check Function Photo Beam Input

LO Linx Module Connection Diagram:

- | | |
|---|------------------------------|
| 1. Motor | 8. Bodyguard |
| 2. Stall 1 | 9. Auxiliary |
| 3. Stall 2 | 10. Photo Beam – TX / RX |
| 4. Sensor – Eagle 1 | 11. Switch – On/Off/Hold |
| 5. Sensor – Eagle 2 | 12. To Control |
| 6. Sensor – Door 1
Door Mounted Sensor | 13. Power 12 to 24 VAC/VDC |
| 7. Sensor – Door 2
Door Mounted Sensor | 14. Setup – INCR = Increment |
| | 15. Setup – FUNCT = Function |

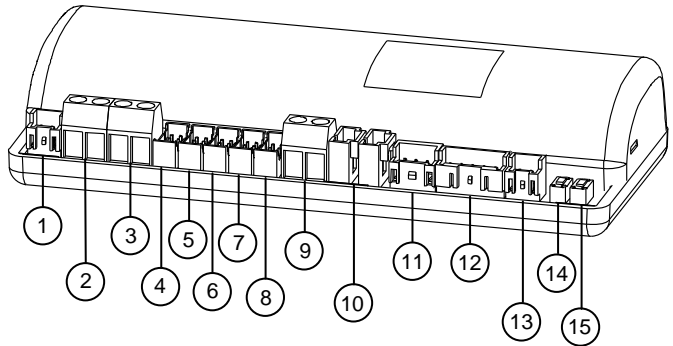

LO Linx Module Installation Components:

<u>P/N</u>	<u>Description</u>
20.5096:	Eagle Harness
20.5071:	SuperScan Harness
20.5082:	Bodyguard Harness
20.5083:	Bodyguard Y Harness (Double Egress Doors)
20.5095:	LO Linx Power Harness

LO Linx Module Installation Components (Continued):

<u>P/N</u>	<u>Description</u>
20.5076:	LO Linx Motor Harness
20.5097:	LO Linx Control Harness
10DOORSWITCH:	On/Off/Hold Switch Assembly
1024VAC:	24 Volt AC Transformer
30.5088:	Wire Nuts

2 Install LO Linx Module

Install the LO Linx Module in an accessible location inside the Door Header using supplied Velcro Strips. Allow adequate space: to easily see the LO Linx Module Display, to access the Push Buttons and to access all Connectors.

3 Install On/Off/Hold Switch

Switch Cable
Route to
'SWITCH'

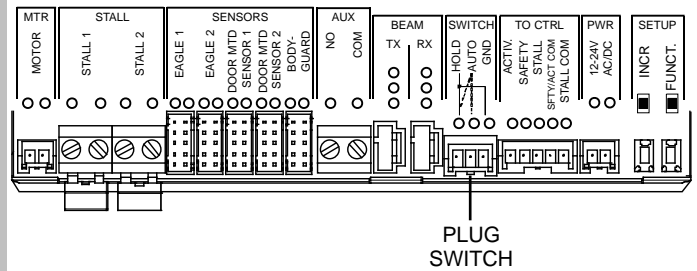
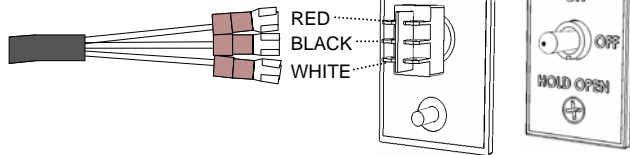

1. Install On/Off/Hold Switch in desired location. Ensure the location is easily accessible to the Store Manager or Owner.
2. Route Wiring Harness P/N 20.5078 from On/Off/Hold Switch to LO Linx and plug into LO Linx Module at location marked 'SWITCH'.

NOTE: When the Switch is placed in Hold Open the door must be activated to enable the door to open and remain in Hold Open mode.

4 Install Bodyguard

Bodyguard Cable
Route To
'BODYGUARD'

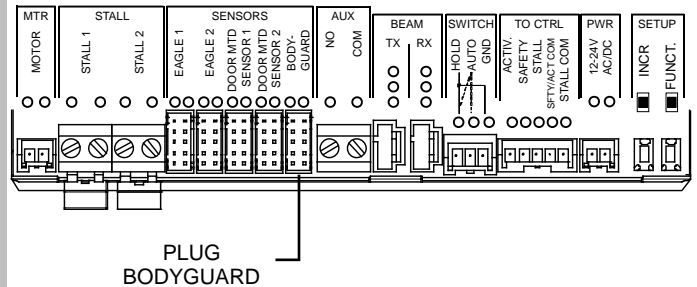
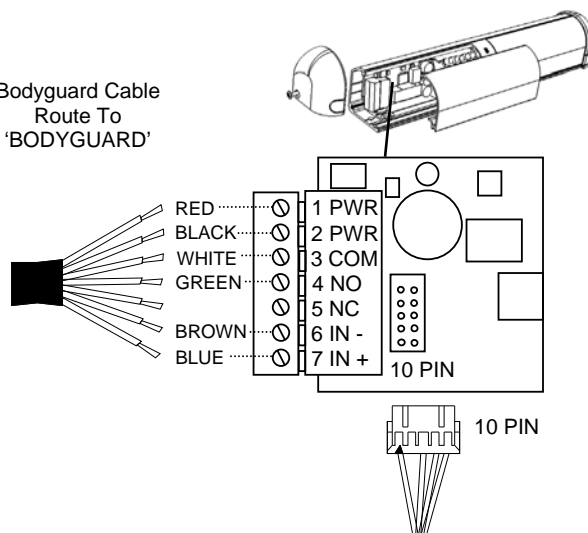

1. For complete installation instructions refer to Bodyguard User's Guide (75.5134).
2. Plug Ten Pin Connector into Bodyguard as shown above, hardwire as shown above only if Ten Pin Connector is not available:
3. Route Bodyguard Cable Harness (20.5082) through Door Header to LO Linx Module.
4. Plug Bodyguard Cable into LO Linx Module, at location marked 'SENSORS', Plug labeled 'BODYGUARD'.

NOTE: For Dual Bodyguard installations use Bodyguard Dual Egress 'Y' Cable Harness (20.5083) along with Bodyguard Cable Harness (20.5082).

5 Install Motor Harness Cable

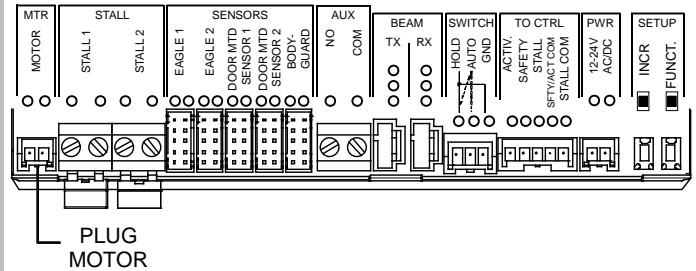
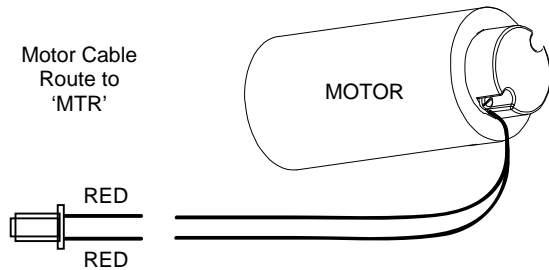

1. Tap into Motor Wires using Two Pin Motor Harness (20.5095). Ensure good connections between Motor and pre-stripped Motor Harness Wires.
2. Plug Motor Harness Cable into LO Linx Module at location marked 'MTR'.

NOTE: No respect to polarity is required.

6 Install Five Wire Harness to Door Control

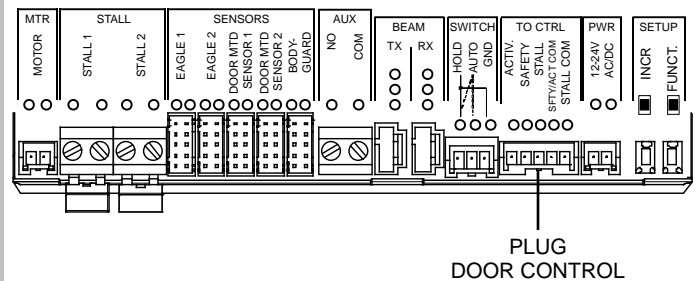
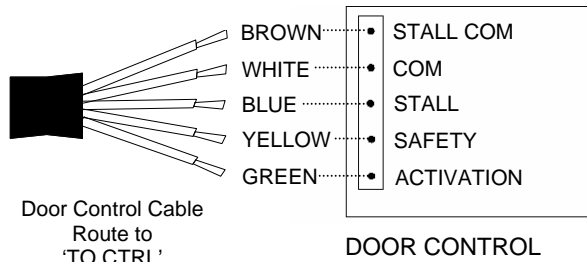

1. Wire Harness to Door Control as displayed above:
2. Plug Five Wire Harness P/N 20.5097 labeled 'To Control' into LO Linx Module at location marked 'TO CTRL'.

NOTE: The Common for Stall Output is isolated from the Common for Activation and Safety. If the Door Control has One (1) Common Input: Tie both Common Outputs from the LO Linx Module together (White and Brown).

7 Connect Power Harness

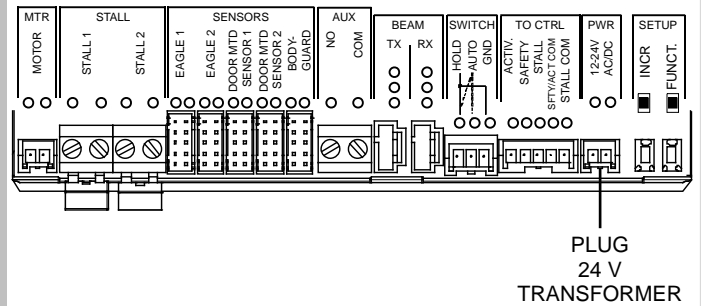
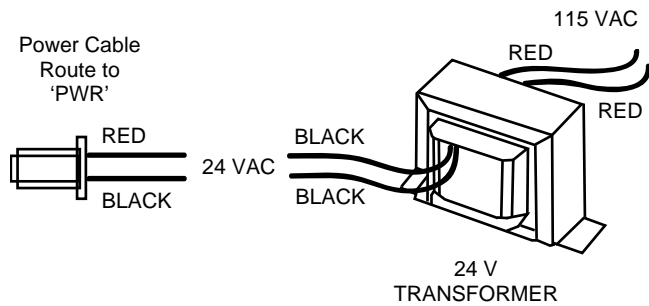





1. Install Transformer in an easily accessible location to the LO Linx Module.
2. Connect Harness P/N 20.5095 labeled 'Power' to 24 VAC Transformer.
3. Plug Harness into LO Linx Module at location marked 'PWR'.

NOTE: A separate Transformer is required to power the LO Linx Module.

8 Bodyguard III Setup

Bodyguard III:

1. Unlock Bodyguard Sensor .
2. Set Output Configuration  to  Normally Closed.
3. Lock Sensor by pressing Lock   two times.

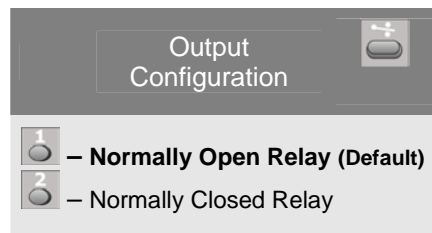
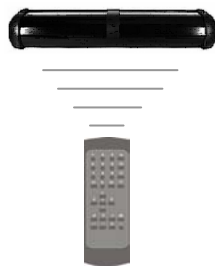

9 Unplug 2-Pin Power Connector

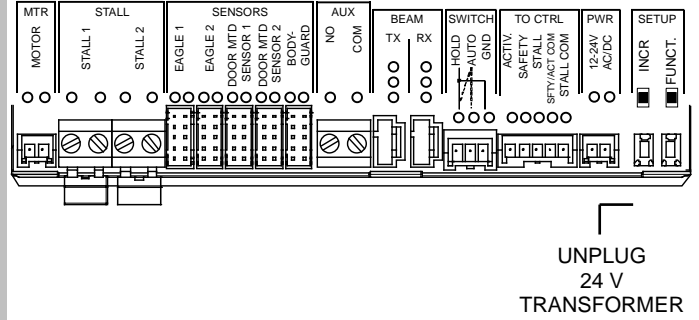
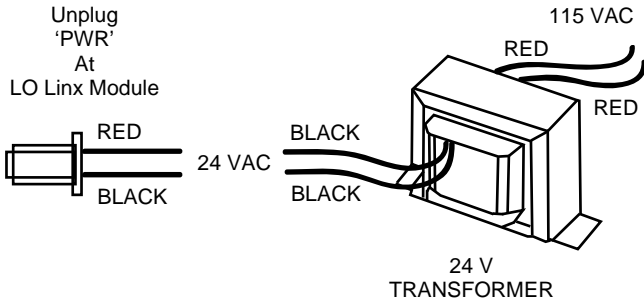

1. Unplug 2-Pin Power 'PWR' Connector from LO Linx Module, wait ten (10) seconds and return power to Connector.
2. Power On and observe the following:
 - Door Mounted Sensors allowed to learn setup (3 sec.).
 - Bodyguard allowed to setup in closed position (3-6 sec. min.).
 - Module learns door closed voltage (3 seconds).
 - Door can be given activation.

NOTE: During power-up, Bodyguard should learn 'Door Closed' position.

10 Activate LO Linx

Door Opens and Remains Open for 10 Seconds.

Bodyguard Sets Up.

Door Closes.

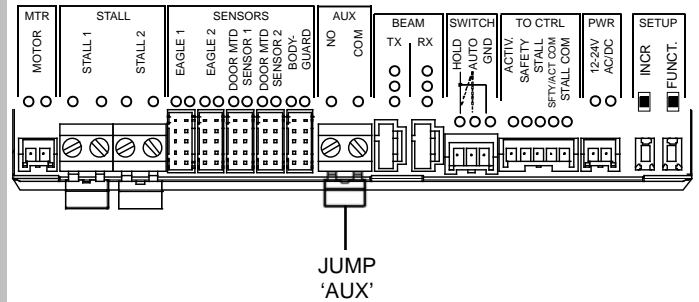
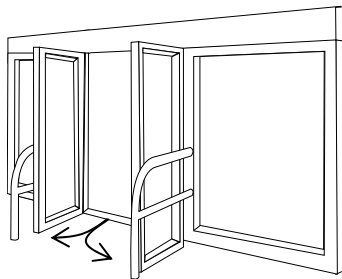

1. Initiate LO Linx Module 'Learn' by activating the LO Linx. This is accomplished by jumping 'NO' and 'COM' of the 'AUX' input.
2. The sequence of events should be observed: Door Opens and Remains Open for 10 Seconds, Bodyguard Sets Up and Door Closes.
 - If a Door Open and Door Closes sequence is successful, then proceed to step 11.
 - If a Door Open and Door Closes sequence is not successful, then refer to Troubleshooting.

11 Check Door Polarity

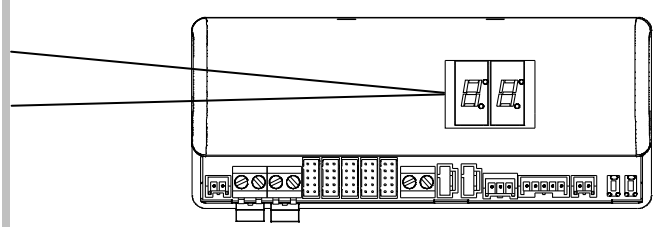
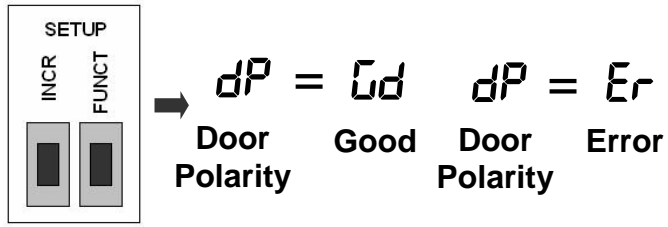

1. Press the 'FUNCT' button until dP is displayed on the Module Display.
 - If dP value is Ud , then continue to next step 12.
 - If dP is Er , then refer to Troubleshooting.

12 Install Activation Device Eagle

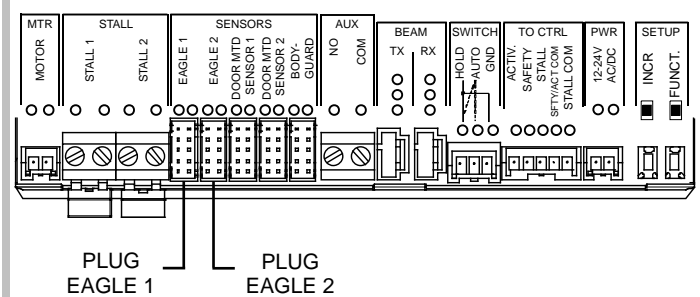
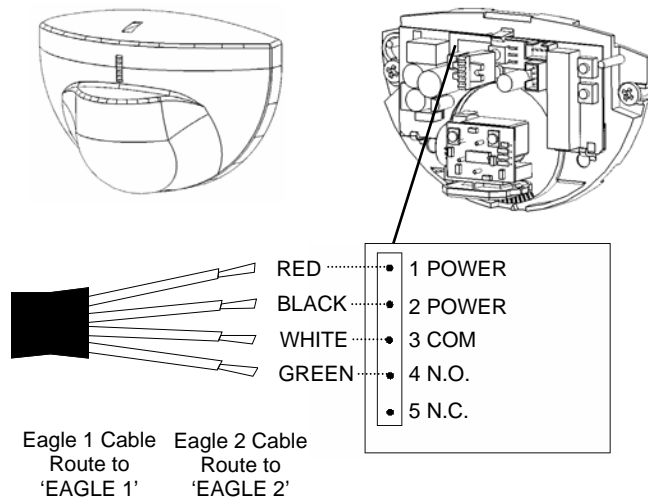

1. For complete installation instructions refer to Eagle User's Guide (75.0058).
2. Wire Eagle as displayed above:
3. Mount Eagle Sensor to Door Header and route Eagle Cable (20.5096) through Door Header to LO Linx Module.

For One Way Door Traffic Installation:

- Plug Eagle Cable into LO Linx Module, at location marked 'SENSORS', Plug labeled 'EAGLE 1'.

For Two Way Door Traffic Installation:

- Plug Eagle Cable into LO Linx Module, at location marked 'SENSORS', Plug labeled 'EAGLE 2'.

13 Install Pushplates

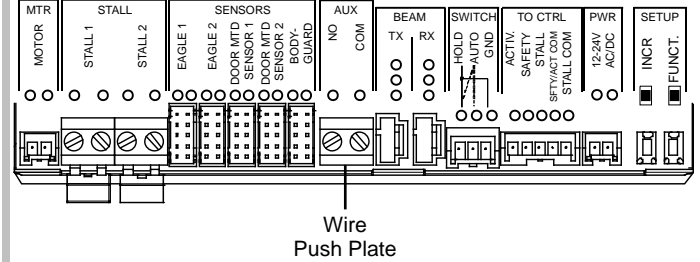
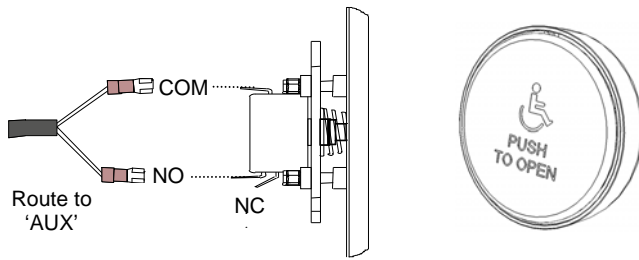

1. Mount Push Plate to Wall, Jamb or desired location accessible to traffic flow.
2. Route wire from Push Plate to LO Linx Module.
3. Using LO Linx Screw Terminal, fasten 'NO' leg of Plate to 'NO' at 'AUX' location on LO Linx Module and 'COM' leg of Plate to 'COM' at 'AUX' location on LO Linx Module.

14 Knowing Act Installation and Setup

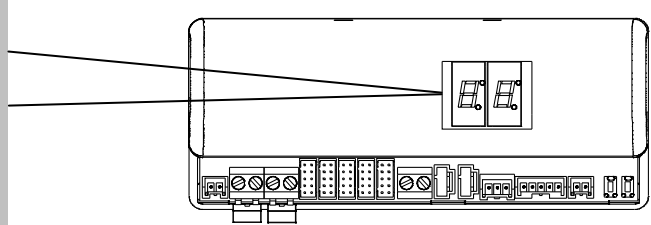
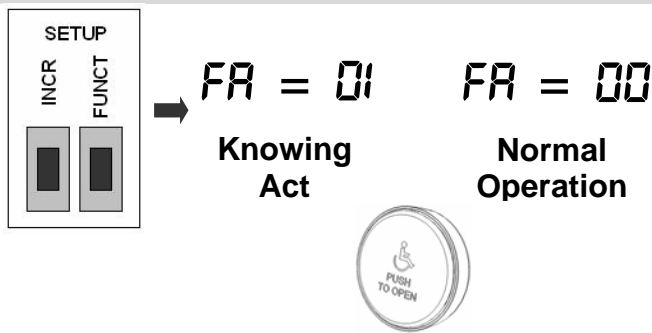

1. For Knowing Act applications where all Activation Devices are required to be disabled when door is in the Closed Position, make the following adjustments to the LO Linx Module:
 - Press 'FUNCT' button until FA is displayed on the LO Linx Module Display.
 - For Knowing Act operation: Set FA to 01 .
 - For Normal Operation: Set FA to 00 .

15 Install Superscan

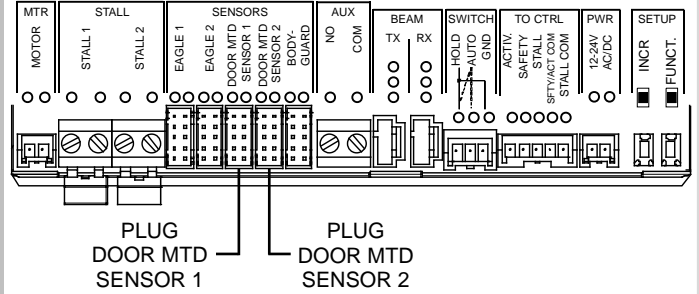
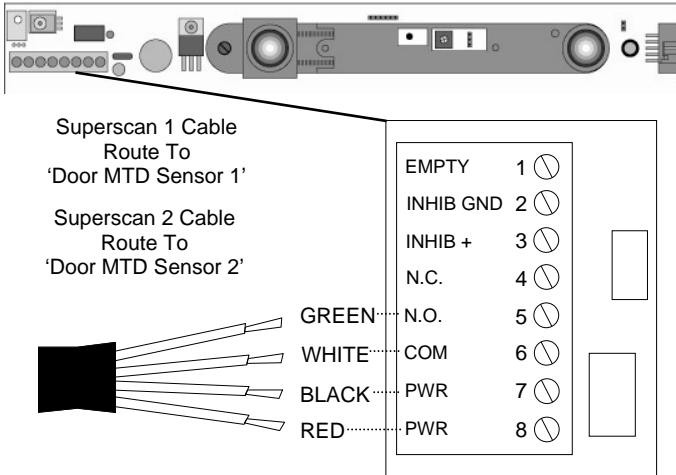

- For complete installation instructions refer to Superscan User's Guide (75.0084).
- Wire Superscan as displayed above:
- Ensure harness labeled **APPROACH** is wired to Activation Side Superscan and harness labeled **SAFETY** is wired to Safety Side Superscan.
- Route Superscan Wiring Harness (20.5071) to LO Linx Module.

For a Two Door Solution:

- Designate Door 1 and Door 2.
- Plug Superscans from Door 1 into LO Linx Module at location marked 'Sensors', Plug labeled 'Door MTD Sensor 1'.
- Plug Superscans from Door 2 into LO Linx Module at location marked 'Sensors, Plug labeled 'Door MTD Sensor 2'.

CAUTION: IF YOU INTEND TO ONLY INSTALL SUPERSCAN SENSOR(S) ON THE SAFETY SIDE (SWING SIDE) OF THE DOOR, PLEASE FOLLOW THESE INSTRUCTIONS:

- Make sure there is no power connected to the sensor(s).
- Identify the SuperScan Harness (20.5071).
- Cleanly cut the cable(s) labeled 'APPROACH'.
- Cap each wire (4 per harness) individually.
- Ensure each wire is properly isolated.

16 Check Function Stall Logic

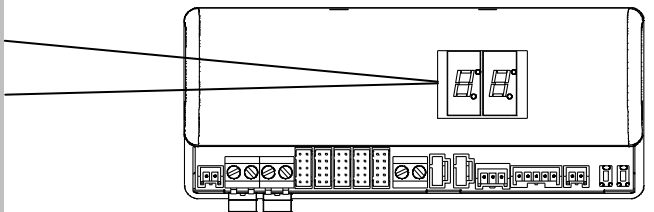
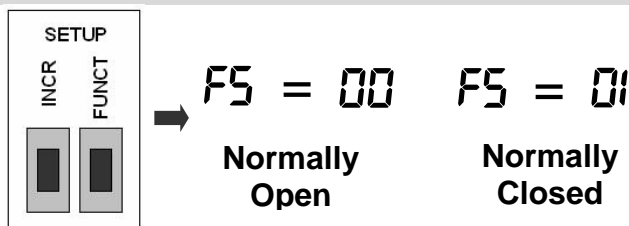

NOTE: Some door operators require Normally Closed stall circuits.

- Adjust Stall Output on LO Linx Module by pressing 'FUNCT' until **FS** is displayed on the LO Linx Module Display, then pressing 'INCR' button until **01** is displayed on the LO Linx Module Display. Default Value is **00** which denotes Normally Open stall output.

17 Install Photo Beam SBK-30

Beams TX Cable
Route to
'Beam TX'



Beams RX Cable
Route to
'Beam RX'

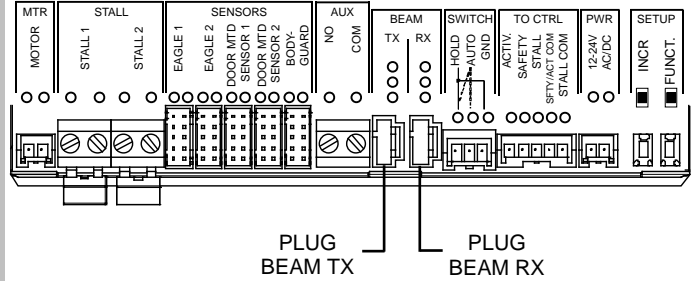
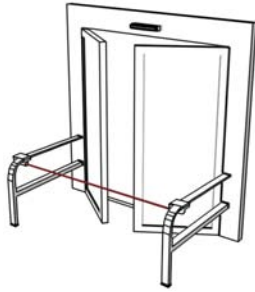

1. For complete installation instructions refer to Beams SBK-30 User's Guide (75.5179).
2. Route Beam TX Cable to LO Linx Module.
3. Route Beam RX Cable to LO Linx Module.
4. Plug Beam TX Cable into LO Linx Module at location marked 'BEAM TX'.
5. Plug Beam RX Cable into LO Linx Module at location marked 'BEAM RX'.

18 Check Function Photo Beam Input

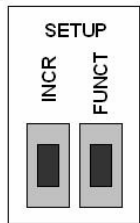

FP = 00 **FP = 01**

**Normally
Open**

**Normally
Closed
SBK-30**

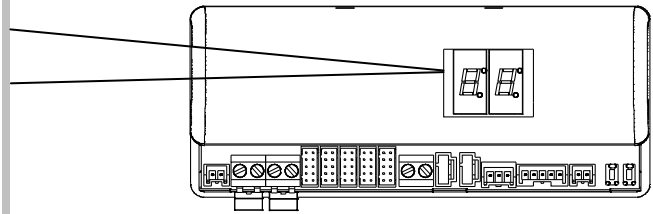

1. When using SBK-30 Photobeams, set the FP variable on the LO Linx Module by pressing the 'FUCNT' button until FP is displayed. Then set to 01 .

6 Wiring

TERMINAL IDENTIFIER	DESCRIPTION	REMARKS
MTR	Motor connection terminal	Provides a parallel connection point to the motor leads. Polarity is not important when connecting the motor wires to the MTR connector.
STALL	Swing Side Superscan terminals	Two positions are available for the Stall circuits. When these terminals are not used, they should be jumpered. The Stall connector merely provides a point to allow easy interruption of the Stall output. If inhibiting of a swing side Superscan is desired at some point in the opening cycle, simply tie the wires coming from the inhibiting switch into Stall 1 (relating to Door MTD Sensor 1) or Stall 2 (relating to Door MTD Sensor 2). The switch must open its contacts at the desired point of inhibiting (except for the Besam Swing door models whereby a closed circuit may be necessary). For most applications, if no inhibiting is desired, a jumper is required at Stall 1 inputs, and another jumper at Stall 2 inputs.
SENSORS	All Sensors – plug-in connectors	The LO Linx provides easy plug-in connectors for (2) Eagles, (2 sets) Superscans and (1) Bodyguard. Note – for double egress doors, (2) Bodyguards can be used with a BEA 'Y' cable. Connections are left blank if no sensor is desired for that particular input EXCEPT the Bodyguard. A Bodyguard sensor must always be plugged in to allow operation.
AUX	Push Plate terminal or RF Receiver	This terminal allows an interface for use with push plates or other generic 'Knowing Act' devices with a 'dry' contact output. This input works whether or not the module is programmed for Knowing Act.
BEAM	Safety Beam plug-in connectors SBK-30	The LO Linx works with the BEA SBK-30 safety beam set. A plug-in connection of the beam is all that is required. Connection points are marked TX (transmitter) and RX (receiver). A beam interruption during the closing cycle allows the inhibiting to the Bodyguard sensor to cease, thus enabling overhead presence detection for the remainder of the closing cycle.
SWITCH	On-Off-Hold Switch plug-in connector	An On-Off-Hold switch kit comes with the LO Linx. No other switching is required. The Module will not operate without the switch.
TO CTRL	Outputs to Door Control	Within the door control output, there is one activation output, one safety output, and one stall. There are two separate (isolated) 'Com' connections, one for stall, and one for the activation and safety circuit.
PWR	Input Power to LO Linx	Module input power must be 12 to 24 VAC/VDC: +/- 10%
SETUP	Program Buttons	There are two buttons provided for programming the LO Linx module. FUNCT allows scrolling through each function, while the second button, INCR, allows toggling through the values for each function. Refer to the 'Programming' section of this manual for further instruction.

7 Programming

- Very little programming is required on the LO Linx, as it automatically recognizes motor voltage conditions to facilitate a 'smart' setup. The LO Linx can display two sets of information for the user interface operating parameters and programming parameters. The first provides a set of real-time operating parameters. These displays are available only to view, with no user interaction possible. They merely provide the operating status of the system. The chart below shows these displays.

NOTE: Function displays are accessed by momentary presses of the 'FUNCT' function button and values are changed by momentarily pressing the 'INCR' increment button.

- DISPLAY TIME-OUT: Allows the user to adjust the Display Timeout to 60 seconds for Setup or Troubleshooting.

- When Display reads **L a**, press and hold INCR button for 5 seconds. This will change the Default Setting (20 seconds) to 60 seconds.
- To switch back to Default Setting (20 seconds), press and hold INCR button for 5 seconds when display reads **L a**.

DISPLAYS	DESCRIPTION
r n	Run Mode – Shows status of outputs: R c - Activation Output 5 F - Safety Output 5 S - Stall Output
d d	Display Door – Shows current state of door position: o P - opening d o - door open d c - door closed c L - closing

PROGRAMMING THE LO LINX (Continued)	
DISPLAYS	DESCRIPTION
dS	Display Sensors –Shows which sensors are in detection: <i>RE</i> - Activation Eagle <i>RP</i> - Activation Push Plate <i>Sb</i> - Safety Bodyguard <i>SP</i> - Safety Photoelectric Beams <i>SS</i> - Safety - Stall side door-mounted sensor
dP	Display Polarity – Value will read Er when there is an error within the connected motor circuit to the module, and Ed when voltage/polarity is acknowledged and within acceptable limits.

- Remember when troubleshooting, these displays can be extremely helpful in quickly identifying possible causal conditions.
- The second set of displays is for programming the module, and allows the user to access and change the values as needed. The chart below explains each function and the possible values for each. For a typical application on most operators, the default settings should suffice.

NOTE: All Functions are defaulted to: **00**

FUNCTIONS	DESCRIPTION
Fc	Function Closing door sensitivity - Changes motor sensitivity for the door-closing to door-closed cycle transition. The values range from 00 to 30 . As the value is increased, the greater the sensitivity of the motor recognition circuit, and thus a faster expiration of lockout time when reaching the closed door position.
FR	Function Knowing Act – Changes the ability to turn off Eagle 1 & Eagle 2 Inputs when the door is closed. 00 = Normal (Default). Knowing Act function is disabled 01 = Knowing Act function is enabled When the Knowing Act function is enabled, initial activation must occur at the AUX Input near the center of the module. All other activation inputs will then be active until the door is fully closed again. Important Note: When FR = 01 , and the On-Off-Hold Switch is placed to a 'Hold Open' position, the AUX input must be triggered once (by Push Plate for example) to cause door to go open. It will then remain in Hold Open until the Switch is returned to the On or Off Position.
Fh	Function Hold – Allows user to add up to 60 seconds of hold time. 05 to 60 = Timeout in Seconds (05 Default). NOTE: Function Knowing Act (FR) must be enabled (FR = 01) for Fh to be active and useable.
FS	Function Stall Logic – Changes the acceptable stall output logic to the door control. 00 = Stall output logic is normally open. 01 = Stall output logic is normally closed.
FP	Function Photobeam Input – allows the use of an SBK-30 lockout beam. 00 = Normally Open Input 01 = Normally Closed Input. Apply this setting when using BEA SBK-30 beam set.
Fd	Function Delay – Allows user to adjust extra lockout time if needed for Bodyguard when door is closing. Adjustable from 0-10 seconds. NOTE: Only used when Bodyguard comes on before door is completely closed.

8 Documentation

- Document all work. For future reference, be sure to record the LO Linx serial number on your work order. It is also a good idea to record all function settings (on your work ticket) that were programmed into the LO Linx.
- Educate the Owner / Manager as to the proper operation of the door and sensor system, and what to do to ensure safe use of the door in the event of discovering a malfunction. Show the Owner / Manager how to perform a daily safety check of the system.
- Be sure to obtain signatures on your work order for all work accomplished.

9 Troubleshooting

PROBLEM	PROBABLE CAUSE	CORRECTIVE ACTION
LO Linx is not showing any display.	Incorrect power input.	Check input power. Must be 24 volts AC +/- 10%. Ensure input power is applied at the correct terminals. A 24 volt AC transformer must be used. Do not power from door control.
	Faulty module.	Replace module.
Door will not open	No inputs connected.	Connect (as a minimum) the On-Off-Hold Switch and the Bodyguard.
	Safety Beam input FP is set incorrectly.	Check function FP at the module. If no SBK-30 beams are plugged into the module, value should be set to 00 . If SBK-30 are plugged in, value should be set to 01 .
	On-Off-Hold Switch in wrong position or is faulty.	Check status of On-Off-Hold Switch.
	Motor recognition dP is in Error.	Check function dP at the module. If indication is Er , then launch a new motor learn at the module. Power Off then Power On to launch a new setup.
	Outputs to Control not connected or faulty.	Verify connections.
	Bodyguard Relay Setting not correct.	Verify Relay Configuration.
	Bodyguard data setting not correct.	Ensure Bodyguard data F1 = 2.
	LO Linx function FR set to 01 when no AUX is used.	Function FR set to Knowing Act 01 without AUX inputs used i.e. Pushplates, etc
	SBK-30 Beams misaligned.	Align Beams.
	SBK-30 Beams Faulty.	Replace SBK-30 Beams.
	Swing side Superscan in Detection.	Adjust Superscan as needed.
	Superscan wiring not correct.	Correct Superscan wiring as needed.
	Superscan no power to Stick.	Check wiring.
Superscan JP 2 in wrong position.	Set to Default.	
Superscan Bad	Replace Superscan.	
Door will not close.	No inputs connected.	Connect (as a minimum) the On-Off-Hold Switch and the Bodyguard.
	On-Off-Hold Switch in position Hold Open.	Check On-Off-Hold Switch position.
	Safety circuit is being held active.	Check function dS at module.
	SBK-30 Beams misaligned.	Align Beams.
	SBK-30 Beams Faulty.	Replace SBK-30 Beams.
	SBK-30 on LO Linx FP set to 00 .	Set SBK-30 on LO Linx to 01 .
	Approach side Superscan in Detection.	Adjust Superscan as needed.
	Superscan wiring not correct.	Correct Superscan wiring as needed.
	Superscan no power to Stick.	Check wiring.
	Superscan JP 2 in wrong position.	Set to Default.
Superscan Bad	Replace Superscan.	
Door keeps recycling open (ghosting).	Activation sensor 'seeing' the door movement.	Adjust motion sensor or door mounted sensor at non-swing side.
Bodyguard Flashing Orange		Ensure Bodyguard data F1 = 2.
		Check data wires. Harness could be a problem.
Bodyguard comes on before door is fully closed.	Needs custom delay setting.	Adjust Fd variable; walk test door while closing to ensure correct time setting (0-10 seconds).

10 Company Contact



CAUTION

Do not leave problems unresolved. If a satisfactory solution cannot be achieved after troubleshooting a problem, please call BEA, Inc. If you must wait for the following workday to call BEA, leave the door inoperable until satisfactory repairs can be made. Never sacrifice the safe operation of the automatic door or gate for an incomplete solution.

The following numbers can be called 24 hours a day, 7 days a week. For more information, visit www.beainc.com.

Canada: 1-866-836-1863
 US and Canada: 1-866-249-7937
 Northeast: 1-866-836-1863

Southeast: 1-800-407-4545
 Midwest: 1-888-308-8843
 West: 1-888-419-2564

11 Wiring Diagram

For complete and up to date LO-Linx Wiring Diagram information go to: www.beasensors.com
 Select Americas/English; Click on 'Download' (top of page); Click on 'Wiring Diagrams' tab; Click on 'Complete WDM' link under LO-Linx.

For direct access to the wiring diagram information on the BEA, Inc. web site go to:
http://www.beasensors.com/BEA/INC/Downloads/WDM/LO_Linx/80.0250.00_LO_Linx_WDM.pdf

