

# USERS GUIDE MC-15

## SAFETY MODULE & LOCK OUT RELAY

### PRODUCT DESCRIPTION

The microprocessed MC-15 Safety Module & Lock Out Relay (PN:10MC15) is designed to add safety to automatic door operators that are designed without a safety circuitry such as, Keane Monroe 2000 or TB8 and Gyro Tech 700/710. The MC-15 uses the motor and Bodyguard / DK-12 to determine if the swing path of the automatic door is clear and allows the door to open or close. If the swing path of the automatic door is not clear and the door is in the open position, the MC-15 will allow the Bodyguard to hold the door open as long as it detects something. If the door is closed and there is something in the Bodyguard pattern, the MC-15 will prohibit the activation device from opening the door.

The new microprocessed MC-15 Safety Module & Lock out Relay provides a means of blocking out the signal from a Bodyguard presence sensor as it detects the door during its closing cycle, thereby allowing re-activation if necessary.

### TECHNICAL SPECIFICATIONS

DESCRIPTION	SPECIFICATIONS
Power Supply	12-24 Volts AC/DC
Operating Frequency	4 MHz (Microprocessor)
Power Consumption	10 mA at rest, 50 mA Max.
Output	2xSPST Relays
Max. Voltage - Relay Contact	60V DC, 120V AC
Max. Current - Relay Contacts	2A DC, 0.5A AC

### COMPONENT ID

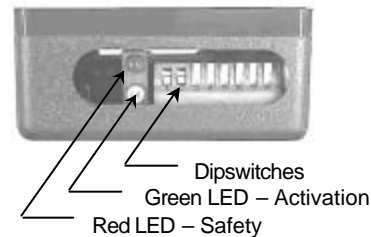

### SAFETY PRECAUTIONS



- Shut off all power going to the header before attempting any wiring procedures.
- Maintain a clean & safe environment when working in public areas.
- Constantly be aware of pedestrian traffic around the door area.
- Always stop pedestrian traffic through the doorway when performing tests that may result in unexpected reactions by the door.
- Always check placement of all wiring before powering up to insure that moving door parts will not catch any wires and cause damage to equipment.
- Ensure compliance with all applicable safety standards (i.e. ANSI A156.10) upon completion of installation.

WIRE CONNECTIONS	
Orange	Power input / 12-24 VAC/DC
Brown	Power input / 12-24 VAC/DC
Red	Motor Input (+)
Black	Motor Input (-)
Purple	Bodyguard / DK-12 N.O.
Gray	Bodyguard / DK-12 COM.
Yellow	Activation Sensor COM
Blue	Door Control: Common
Green	Door Control: Activation
White	Bodyguard / DK-12 Data (-)
Red/White	Bodyguard / DK-12 Data (+) & Activation Sensor N.O.

Please note that the following provisions must be made when wiring into an operator that is hydraulically driven or has an AC motor. The red and black wires from the MC-15 must be wired to the voltage source that is driving the operator. Typically, this can be found at the AC motor, pressure relief solenoid, or selector valve. If the AC voltage at these locations is greater than 50 V AC, then a 10,000 Ohm resistor must be wired in-line with the red wire. This resistor, along with two butt splice connectors are provided by B.E.A. in each MC-15 package. The Keane Monroe 2000 electro-hydraulic operator is an example of an AC operator.

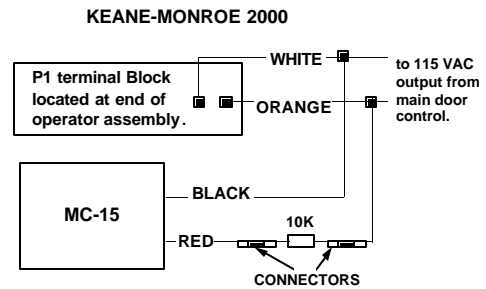
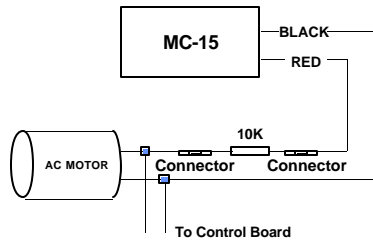

**MC-15 WIRING DIAGRAM - Typical**

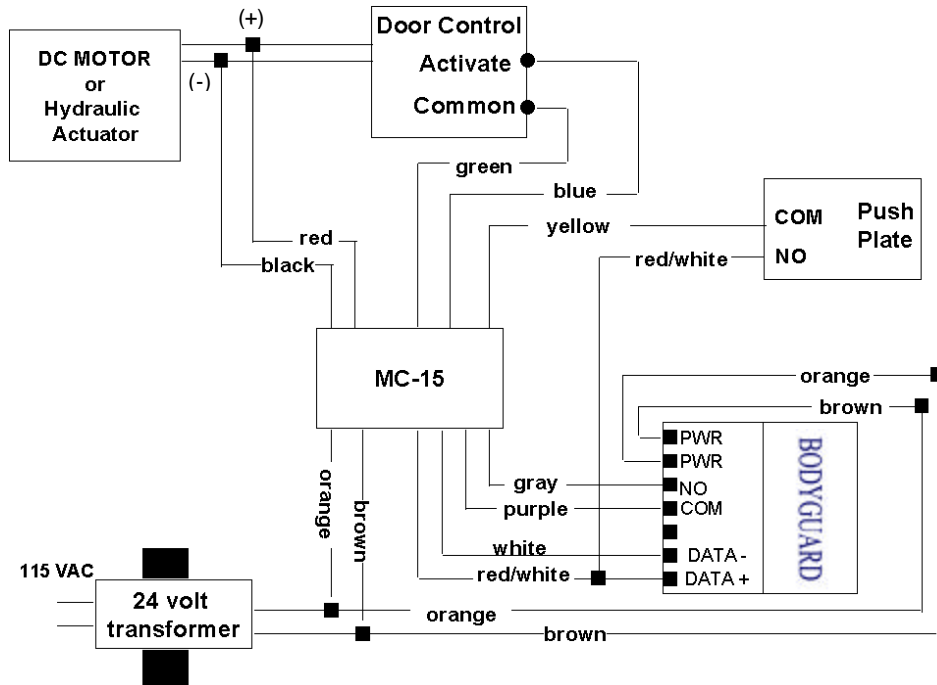

Upon completion of all wiring, proceed with the set-up as follows:

1. Insure that the On-Off-Hold Open switch is in the ON position, and insure that the door control is powered and operating normally.
2. Power the MC-15 on with 12-24 VAC/DC, and insure all sensors or other devices in the application are properly powered
3. Observe the green LED on the Bodyguard upon powering. With the door in the closed position, the green LED should begin blinking, then expire approximately 5 seconds thereafter to indicate a successful set-up for the closed-door position.
4. Activate the door to the open position, the Bodyguard should once again begin flashing green, then expire approximately 5 seconds thereafter to indicate a successful set-up for the open-door position.



If the Bodyguard learns a "door closed" position, but does not execute a set-up for the "open door position", place the door to a hold open position. With a BEA remote control, unlock the Bodyguard, and with the door in the open position, press the Magic Wand key and then the number 2 – the Bodyguard should begin flashing green to signify a set-up. If it does not, this will be a quick indication that the improper data is being sent for the "open door" position. Check to insure that data exists on the data lines leading into the Bodyguard. In the full open position, voltage should be approximately 12 volts DC. If it is not, check the data lines (Red/White and White wires) for correct voltage (see chart), as well as the MC-15 Motor wires (red & black). Refer to the Bodyguard User's Guide for further information if necessary.

CLOSED DOOR	OPEN DOOR	CLOSING DOOR
0 Volts DC	12 Volts DC	8 Volts DC

5. Once the Bodyguard has learned the open and closed door positions, observe the green and red LED's on the MC-15. Walk in and out of the field of detection for the Bodyguard while the door is open, and then again when it is closed. The LED's indicate the following:

- GREEN LED: The green LED, when illuminated, indicates that there is detection at the Bodyguard while the door is in the open position.

If someone steps into the Bodyguard detection zone when the door is open, the MC-15's Green LED will illuminate to indicate that the Bodyguard will be connected to the activation circuitry of the door, thus holding the door open as long as there is detection.

- RED LED: The red LED, when illuminated, indicates that there is detection at the Bodyguard while the door is in the closed position.

When the door is closed, and someone steps into the safety zone of the Bodyguard, the red LED on the MC-15 will illuminate, indicating that it will ignore any activation signal it receives. Therefore, the door will remain closed until the Bodyguard detection zone is clear. Once the Bodyguard zone is clear and the door has been activated it will open and remain open for the hold time set by the motion sensor and/or door control.

**NOTE:**

If the door goes into safety swing as soon as it starts to close and you have a time delay set for the length of the closing cycle, reverse the black and red wires to the motor input for DC units. If the unit is AC, ensure that the AC power is being switched on and off at the point of connection for the red and black wires. Correct any faults before proceeding.

6. The only adjustment required for the MC-15, is to configure the dipswitches to obtain the necessary lock out time delay. To set the dipswitches( 1 through 5) for lock out time, perform the following:
  - Activate the door to the open position.
  - Time the overall door closing cycle
  - Configure the dip switches according to the chart on Page 4 for the lockout time that is required
  - Activate the door again to the open position
  - Stand outside of the Bodyguard detection pattern, and while the door is closing, observe the red LED on the Bodyguard
  - The red LED on the Bodyguard should NOT illuminate during the closing cycle. If it does, it is probably seeing the door at the very last degree or two of door closing, which would indicate that the lock out time needs to be slightly increased.
  - Reconfigure the dipswitches to add 1 second of lock out time.
  - When the lock out time is correct. The red LED will not illuminate during the entire closing cycle of the door.
7. The last test is to insure that the Bodyguard detects an object as soon as the door has stopped closing. Simply allow the doors to begin closing, and step in behind the doors, into the Bodyguards field of detection (be sure to NOT break the path of the lockout safety beams, if so equipped). The red LED shall illuminate and remain on at the Bodyguard, and at the MC-15, as soon as the door reaches the fully closed position, provided that an object remains in the Bodyguard's detection field.

**DIPSWITCH  
SETTINGS**

Set the dipswitches according to the chart below to achieve the desired lockout time. The total lockout time is the sum total of the dipswitches that are in the ON position. For easy reference, use the timetables below.



Dipswitch #	Time Delay (seconds)
1	1
2	2
3	4
4	8
5	16
6	Not Used
7	Not Used
8	Not Used

**Example:**

The normal closing cycle of an automatic door lasts about 7 seconds. In order to get the proper closing lock out time delay needed for the closing cycle of the door, the dipswitches need to be set according to the chart below for 7 seconds. To get the proper lock out time delay dip switches 1, 2, & 3 must be in the ON position and dipswitches 4, 5, & 6 must be in the ON position and dipswitches 4, 5, & 6 must be in the off position. Default switch setting is 7 seconds.

Time Delay (sec)	dip 1 1 sec	dip 2 2 sec	dip 3 4 sec	dip 4 8 sec	dip 5 16 sec
1	on	off	off	off	off
2	off	on	off	off	off
3	on	on	off	off	off
4	off	off	on	off	off
5	on	off	on	off	off
6	off	on	on	off	off
7	on	on	on	off	off
8	off	off	off	on	off
9	on	off	off	on	off
10	off	on	off	on	off
11	on	on	off	on	off
12	off	off	on	on	off
13	on	off	on	on	off
14	off	on	on	on	off
15	on	on	on	on	off
16	off	off	off	off	on

Time Delay (sec)	dip 1 1 sec	dip 2 2 sec	dip 3 4 sec	dip 4 8 sec	dip 5 16 sec
17	on	off	off	off	on
18	off	on	off	off	on
19	on	on	off	off	on
20	off	off	on	off	on
21	on	off	on	off	on
22	off	on	on	off	on
23	on	on	on	off	on
24	off	off	off	on	on
25	on	off	off	on	on
26	off	on	off	on	on
27	on	on	off	on	on
28	off	off	on	on	on
29	on	off	on	on	on
30	off	on	on	on	on
31	on	on	on	on	on

**COMPANY  
CONTACT**

If after troubleshooting a problem, a satisfactory solution cannot be achieved, please call B.E.A., Inc. for further assistance during **Eastern Standard Time at 1-800-523-2462 from 8am - 5pm.** For after-hours, call East Coast: 1-866-836-1863 or 1-800-407-4545 / Mid-West: 1-888-308-8843 / West Coast: 1-888-419-2564. **DO NOT leave any problem unresolved.** If you must wait for the following workday to call B.E.A., leave the door inoperable until satisfactory repairs can be made. **NEVER sacrifice the safe operation of the automatic door or gate for an incomplete solution.**  
web: [www.beasensors.com](http://www.beasensors.com)