

PRESENCE SENSOR

DESCRIPTION

The SuperScan (10SSI, 10SSII, 10SSIII) detector is a door-mounted presence detection system that is used on automatic pedestrian swing doors. The SuperScan can be used on an SMR or non-SMR system. Unlike other door-mounted sensing devices, the SuperScan's unique electronic architecture allows the detection modules to be mounted near the top of the door, out of harm's way. A rotating cam is used for the range adjustment of the detection zone. Width patterns may be altered by adding slave modules to the master module. These slave modules are simply added by inserting them into the aluminum extrusion, then connecting them with the attached flat ribbon cable to the next module without interrupting other modules in the same extrusion. Once installed, the detection zone (in addition to being adjustable for distance) can be angled independently from the other modules.

Each SuperScan module consists of two optics, a transmitter (TX) and a receiver (RX), and functions independently of the other modules. The transmitter emits an extremely precise beam, which measures approximately 4" in diameter at a distance of 8'. The receiver, in turn, receives the infrared beam reflected off of the floor. This transmission and reception forms a detection triangle, which is the basic premise of detection (called triangulation). Should this angle be interrupted, detection will occur. Detection is NOT based upon the intensity of the beam, and in principle will not be affected by the color or background of the object that interrupts the angle.

TECHNICAL SPECIFICATIONS

DESCRIPTION	SPECIFICATION
Power Supply	12 to 24 VAC \pm 10% / 12 to 24 VDC \pm 10%
Current Consumption:	Master: On = 60 mA max. / Master: Off = 30 mA max. Slave: On = 40 mA. Max. / Slave: Off = 30 mA max.
Input Inhibit	12 to 24 VAC \pm 10%: / 12 to 24 VDC \pm 10% / Inhibited when voltage is applied
SMR Input Data	12-18 VDC: Inhibited when voltage is applied
Output Interface; relay	Relay; max. contact rating is 1A @ 30v (resistive)
Detection Range	0' to 8'
Distance Adjustment	2' to 8' / Rotating cam with linear adjustment
Max. Mounting Height	8'
Detection Time	< 50 ms
Detection Signal Duration	Infinite Presence Detection
Output Hold Time	Potentiometer Range: 0.1 to 4.5 seconds.
LED Indications	Master: Red LED = Detection Green LED = Active Output Slave: Red LED = Detection
Operating Temperature Range	-30° F to 140° F
PCB Dimensions	Master: 10.91" x 1.5" Slave: 8.75" x 1.5"
Connection to Door Controller	8 Position Screw Terminal on Master PCB
Connection: Master to Slave	Flat Ribbon Cable With Connectors and Key Lock
Max. Number of Slaves	Standard = 9 / With Monitoring = 8 max.
Functions Selection	Detection Mode - NO or NC Normal Mode or Background Analysis Mode

COMPONENT ID

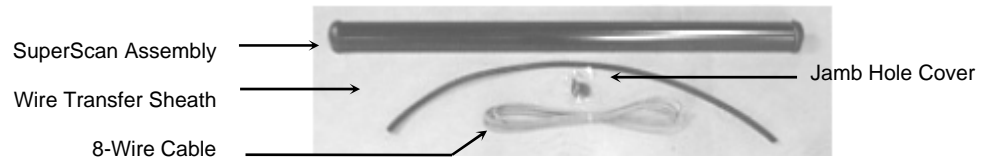

INSTALLATION TIPS

- The sensor must be firmly fastened to prevent vibration.

- Sensor must be in a location that does not interfere with door hardware (finger guards, lock rods, etc.).

- The sensor must not have any unwanted objects likely to move or vibrate in its path.

**SAFETY
PRECAUTIONS**



CAUTION

- Shut off all power going to the header before attempting any wiring procedures.
- Maintain a clean & safe environment when working in public areas.
- Constantly be aware of pedestrian traffic around the door area.
- Always stop pedestrian traffic through the doorway when performing tests that may result in unexpected reactions by the door.
- Always check placement of all wiring and components before powering up to ensure that moving door parts will not catch any wires and cause damage to equipment.
- Ensure compliance with all applicable safety standards (i.e. ANSI A156.10) upon completion of installation.

**MECHANICAL
INSTALLATION-
PREPARING AND
MOUNTING THE
SENSOR**

1. Remove the screw that secures the end cap to the SuperScan extrusion (as shown in Picture 1 below).



2. Remove the plastic lens by pulling the lens out from the top of the extrusion (as shown in Picture 2 above). Do not use a screwdriver to pry the lens, as cracking may occur.



CAUTION: Remove the master and all slave circuit boards from the aluminum extrusion before performing any drilling. When complete, ensure that all metal shavings are cleaned from the extrusion before re-inserting the circuit boards.

3. Picture #3 below shows the angle adjustment clip in its proper position within the extrusion (PCB's are removed, and clip is shown at end of extrusion for clarity only). To remove the clip, simply pull the tab out away and downward from the extrusion, then rotate the module out from extrusion as shown in picture #4. To re-install, simply reverse the procedure - the PCB must first be installed into the adjustment clip, then installed into the aluminum extrusion.

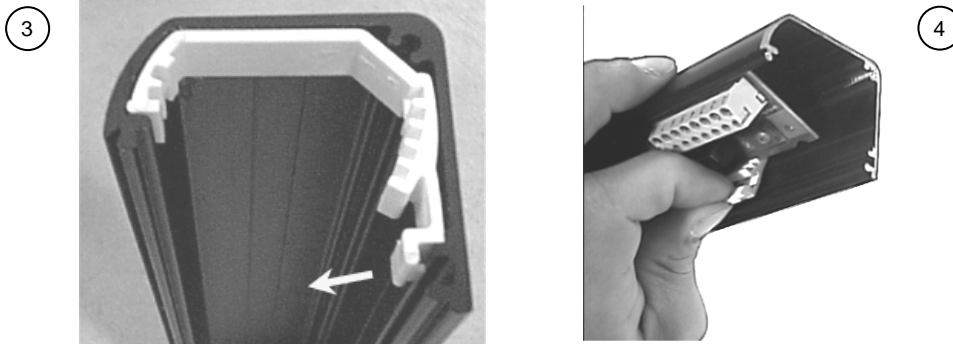

IMPORTANT NOTE: The end of the extrusion that is towards the pivot end of a center hung door, should be in far enough from the edge of the door, as shown in picture #5, to prevent the end cap of the SuperScan from rubbing against the finger guard during door movement. Pay particular attention on the safety side of the door. Hinge hung doors will not require as much clearance between the end of the SuperScan and hinge-side jamb as shown in picture #6 below. At the leading edge of the door, the edge of the SuperScan, including the end cap, should be as close as possible to the leading edge of the door, without creating mechanical interference with the door jamb or with an adjacent door (pairs).



- Hold the SuperScan extrusion up to the top of the door. Insure that the extrusion is oriented correctly as shown below.

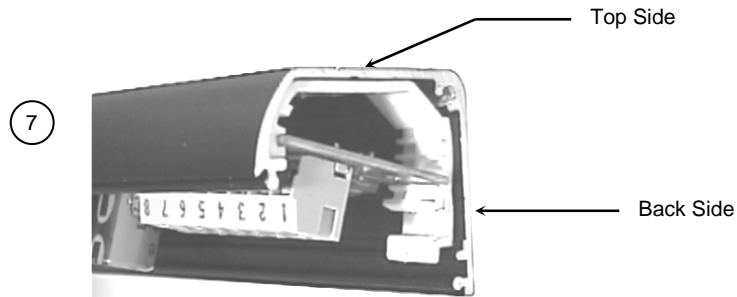

- Mark and drill the extrusion (in the approximate locations as shown below) where the mounting holes (one at each end) should be located. Also, be sure to mark and drill the proper end for an additional hole to be used for wire passage. Wire passage hole should be approximately 1/4" diameter. Screw mount holes only serve as a pilot hole for ease of installing the self-drilling screws that are provided.

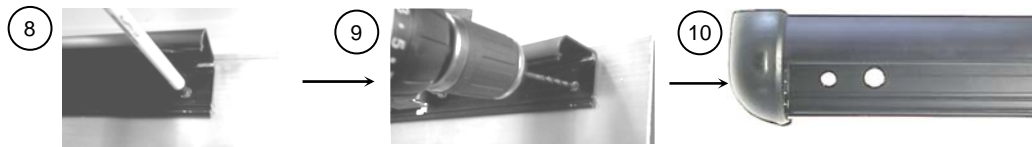

NOTE: Take care to avoid screw holes near the seams of the door, where it may be difficult to drill and install a screw, and possibly damage the inside structural braces of the door.

- Hold the SuperScan back up to the door at the pre-drilled location and attach the unit to the door with the 2 screws provided. Insure that the SuperScan extrusion is tight against the door.

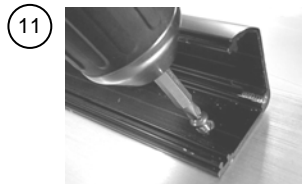

- If SuperScans are to be mounted on both sides of the door, a wire passage hole will be required through the door to go from the approach side to the safety side, as shown below. Again, be sure not to drill through any through-bolts or braces within the door. A cutaway view below (Picture 13) shows wire passage through the door. Picture 12 and 14 shows an approximate location for the wire passage hole. The extension wire going between the terminal blocks should be approximately 18" long and can then be cut back if needed.

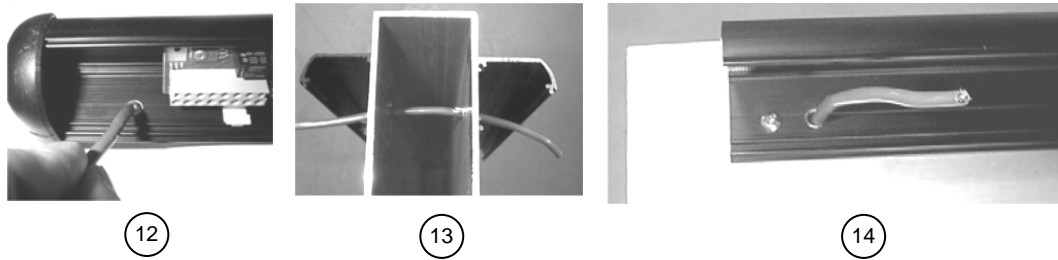

**MECHANICAL
INSTALLATION-
PREPARING AND
MOUNTING THE
SENSOR – Cont.**

8. Next, a wire passage hole will be required in the door header (Picture 15) and also in the jamb tube (Picture 16) at approximately the same height as the SuperScan. The wire transfer hole in the jamb should be at the secure side of the door. Normally this would be the interior side. Feed the wire through the jamb tube up to the header. Insure that enough wire is left out to reach the SuperScan terminal block.

15



16



NOTE: Ensure there is enough slack in cabling to allow adequate movement of the cable throughout the range of door travel.

9. Once all cabling is in place, the plastic sheath must be installed over the wire coming out of the jamb tube. This must be done before making final connection to the terminal block. The sheath may have to be cut to fit the application. Once the wire is fed though, the plastic cap may be installed on the jamb, over the transfer hole.

17



18



19



← Plastic ribbed sheath

**ELECTRICAL
INSTALLATION-
CABLING &
CONNECTIONS**

1. With cabling in place, wiring at the terminal connector on the SuperScan master module (picture 20) may be completed. Wiring will vary according to the application. Available positions on the connector are shown below:

20

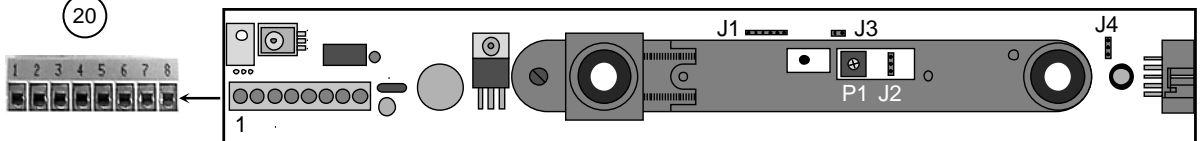

SuperScan Terminal	Explanation of Wiring Connections
1	Test data - used with SMR systems only.
2	Ground. Negative terminal if Input inhibition is used.
3	Input inhibition: All detection is ignored. Infrared emission is stopped. Inhibition occurs when 12 to 24 VAC ± 10% or 12 to 24 VDC ± 10% is applied between terminal 3 and terminal 2.
4 (NO)	In the relay mode, depending on the position of JP2 this terminal will provide either a NO or NC contact. (JP2 factory default will result in NC on terminal 4)
5 (NC)	In the relay mode, depending on the position of JP2, this terminal will provide either a NO or NC contact. (JP2 factory default will result in NO on terminal 5)
6 (COM)	Common contact for relay.
7 (-)	This terminal is used for power input. A voltage of 12 to 24 VAC ± 10% or 12 to 24 VDC ± 10% must be supplied.
8 (+)	This terminal is used for power input. A voltage of 12 to 24 VAC ± 10% or 12 to 24 VDC ± 10% must be supplied.

- Once all wiring has been completed, the end caps and lens may be installed. At the SuperScan end of the cable (picture 23), leave enough slack to allow a relaxed connection at the terminal block. Locate the Superscan end cap that goes towards the hinged end of the door. Remove the tab at the bottom of the cap (picture 21) to allow insertion of the plastic sheath. Insert the plastic sheath (picture 22) and install the end cap. The SuperScan lens may then be installed to fit tight against the end cap and plastic sheath to hold it in place, as shown in picture 24. Leave the end cap off at the opposite end until all mechanical adjustments have been completed.

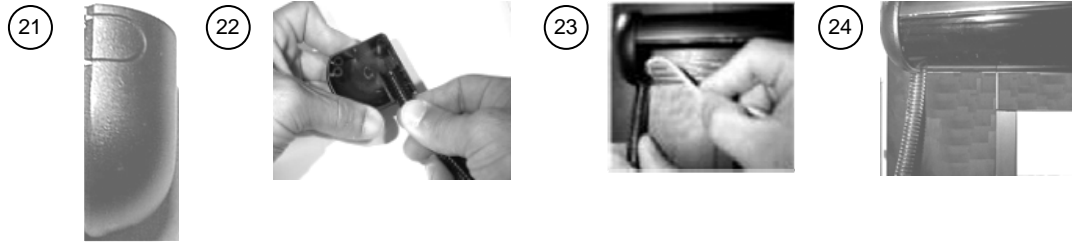

*** Refer to the back of this Guide for various wiring schematics.**

Master & Slave Module Jumper Settings: Prior to power-on, all jumper settings on the master and slave boards should be set according to the installation.

Jumper settings include:

- Function J1: Background Analysis (master & slave boards)
- Function J2: Relay Mode (NO / NC) (master board only)
- Function J3: SMR Mode (master & slave boards)
- Function J4: Master Only or Master & Slave Configuration (master & slave boards)

- Jumper J1, Background Analysis, is a 6-pin (older models) OR 3-pin (newer models) configuration located on each module, as shown below in picture 25 - the location is the same for each. Background Analysis is the ability to analyze the background in the area of the detection field, to help reduce chances of non-detection due to faulty environmental situations. When ON (picture 26), Background Analysis allows constant detection in the event of one or more of the following situations:
 - Module aimed too high
 - Module incorrectly oriented (towards sky for example)
 - Defective amplification chain
 - Faulty infrared transmitter
 - Not enough reflectivity off of floor surface

NOTE: Floor must have at least 5% reflectivity to allow Background Analysis to function properly.

This configuration greatly reduces the chance of allowing the modules to function less than optimally. If one of the above-stated faults exists, the detector will remain active, thereby causing the door to stay open or to not open. This fail-safe operation will cause the door to be inoperative in the automatic mode, since there will be a constant signal either to the safety input or to the activation input of the door control, depending on which module is sensing detection. If an extremely dark floor is present, set jumper to normal mode. **Also set to Normal Mode if using with B.E.A.'s SuperStop Module. The J1 function must be set on each module.**

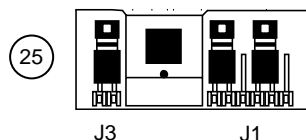
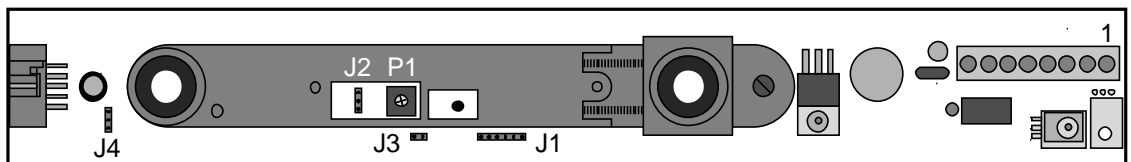

6-Pin
Normal Mode
(Default)

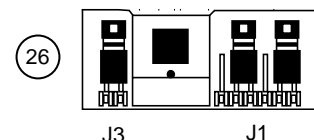

6-Pin
Background
Analysis Mode

Newer Models – 3 Pin Jumper – Shown with same orientation as 6-pin jumper above

- The same logic applies as with the 6-pin: Center and left pin are for Normal Mode, center and right pin are for Background Analysis Mode.

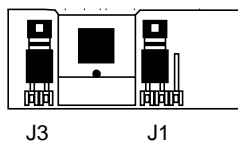

3-Pin
Normal Mode
(Default)

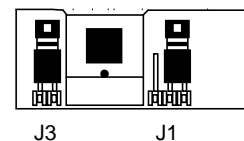

3-Pin
Background
Analysis Mode

2. J2 is a two-position jumper, which enables either a passive or active relay to be selected. The SuperScan comes factory preset with the relay in the ACTIVE MODE. **J2 IS ON THE MASTER BOARD ONLY.**

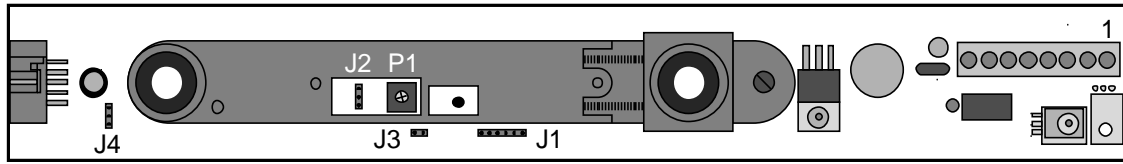

- ACTIVE RELAY: The relay is energized when the detector is at rest.**

3. ACTIVE RELAY + NC & COM TERMINAL CONNECTION = CLOSED CONTACT DURING DETECTION:

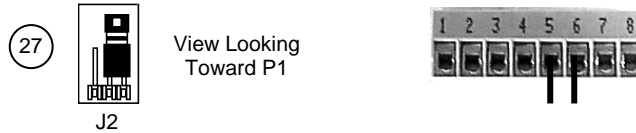

- Use the NC & COM terminals (5 & 6) & leave JP2 at the factory preset position.
- During detection, led indication will be green led OFF, red led ON.
- FAIL SAFE MODE – This means that upon power failure, the contact will be closed.

4. ACTIVE RELAY + NO & COM TERMINAL CONNECTION = OPEN CONTACT DURING DETECTION

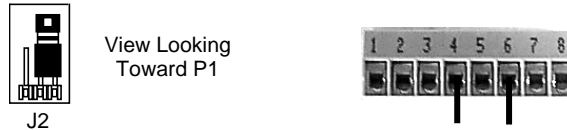

- Use the NO & COM terminals (4 & 6) & leave JP2 at the factory preset position.
- During detection, led indication will be green led OFF, red led ON.
- Upon power failure, the contact will be open.

- PASSIVE RELAY: The relay is de-energized when the detector is at rest.**

5. PASSIVE RELAY + NO & COM TERMINAL CONNECTION = CLOSED CONTACT DURING DETECTION

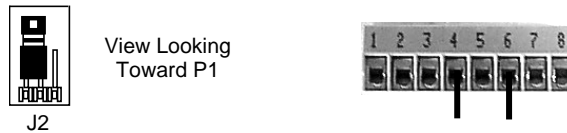

- Use NO & COM terminals (4 & 6) & **CHANGE JP2 from the factory preset position.**
- During detection, led indication will be green led ON, red led ON.
- Upon power failure, the contact will be open.

6. PASSIVE RELAY + NC & COM TERMINAL CONNECTION = OPEN CONTACT DURING DETECTION

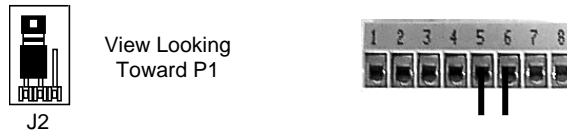

- Use the NC & COM terminals (5 & 6) & **CHANGE JP2 from the factory preset position.**
- During detection, led indication will be green led ON, red led ON.
- Upon power failure, the contact will be closed.

Note:

The safety side SuperScan(s), when connected to a BEA SS-21, need(s) to provide a closed contact when activated.

7. Jumper J3 is to toggle the SMR mode on and off, and is located on the master module only.

- Jumper installed on both pins = SMR OFF (default setting), Picture 28.
- Jumper removed (may be stored on one pin) = SMR ON, Picture 29.
- SMR should be ON only when the SuperScan is being used with BEA's Door Control Unit (DCU).
- SMR is not available on master modules without jumper J3 installed. See page 8 for module configurations.

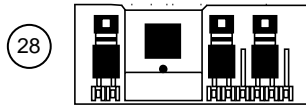
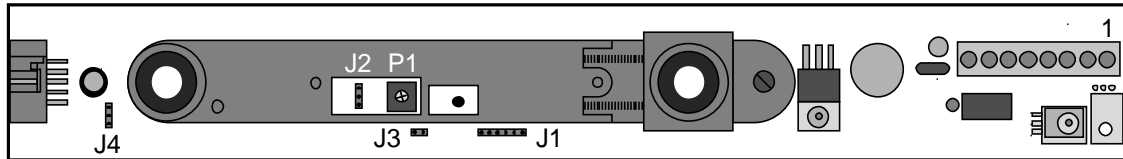

SMR "OFF"

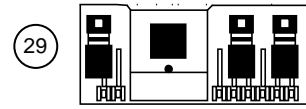

SMR "ON"

8. Jumper J4, is found on the master module, and is also found on the slave module. On the master module, it determines "master only" or "master and slave" configuration for use when SMR is ON. When the jumper is installed in "master only" configuration, as shown below in picture 30, it is intended for use without slave modules added to the chain and is for "master only" operation. The jumper is located at the Output end of the master module. With jumper J4 installed as shown in picture 31, the master is intended for slave modules to be added. Jumper J4 is also installed on the slave module near the output end of the module. SMR is not available on master and slave modules without jumper J4 installed. See page 8 for module configurations.

Master

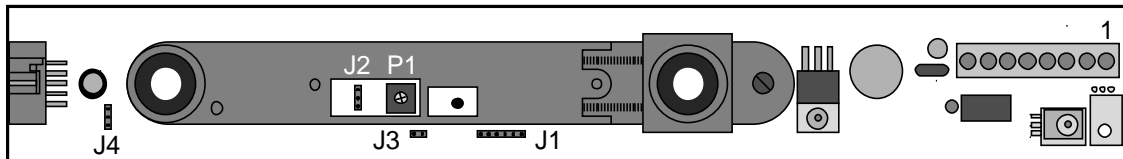

Slave

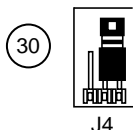
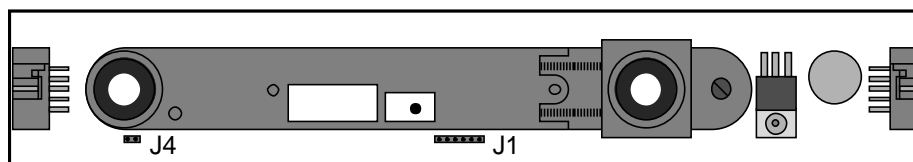

View Looking Toward
Master Output

J4

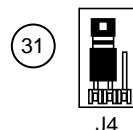

View Looking Toward
Master Output

J4

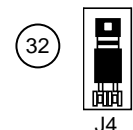

J4

As Shipped From BEA, Inc., default placement of J4 jumpers is as follows:

- If a Master ONLY is shipped: Jumper will be positioned for Master Only
- If a Slave ONLY is shipped: No jumper on Slave J4 position
- If a kit is shipped (i.e. SuperScan II): Jumpers correctly placed for that configuration.

9. On the slave module, jumper J4 should be installed on the last slave module in the chain, as shown above in picture 32. All slave modules between the master and the last slave should have the jumper removed. Latest module configurations without jumper J4 installed can simply be installed in chain with the master and slaves. See page 8 for module configurations.

10. There is a hold-time potentiometer (P1) located on the master module. It is located between the receiver and transmitter. Adjustability ranges from 0.1 to 4.5 seconds. When installed, clockwise rotation increases time delay.



P1

MASTER AND SLAVE MODULE COMPATIBILITY TABLE				
Compatible: ✓ Not Compatible: X		MASTER		
		Config.1 SMR	Config.2 SMR	Config.3 Non SMR
SLAVE	Config.1 SMR	✓	✓	X
	Config.2 SMR	✓	✓	X
	Config.3 Non SMR	✓	✓	✓

MASTER MODULES

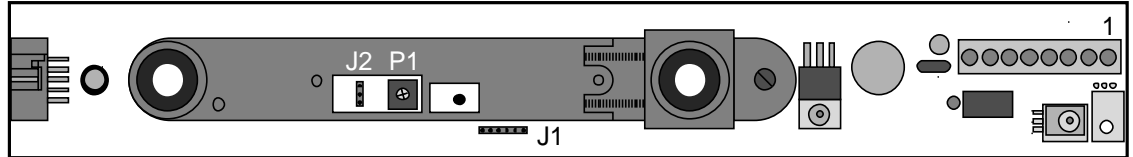

Configuration 3 – Non SMR: Jumpers: J1 “6 Pin” and J2 (Latest Master Module)

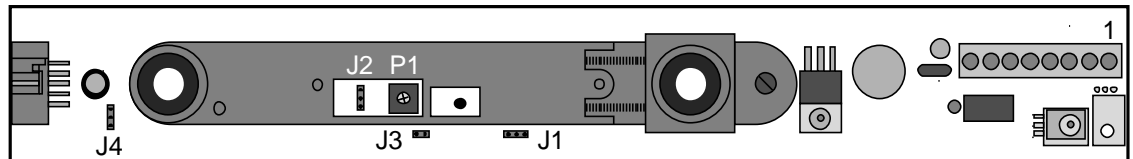

Configuration 2 - SMR: Jumpers: J1 “3 Pin”, J2, J3 and J4 (Subsequent Master Module)

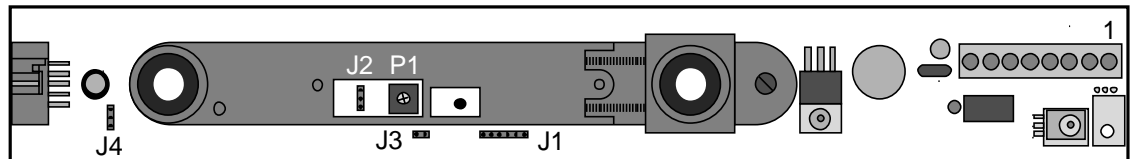

Configuration 1 - SMR: Jumpers: J1 “6 Pin”, J2, J3 and J4 (Earliest Master Module)

SLAVE MODULES

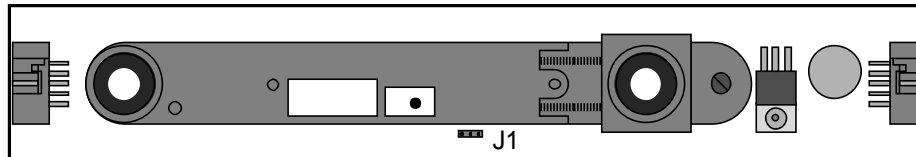

Configuration 3 – Non SMR: Jumper: J1 (Latest Slave Module)

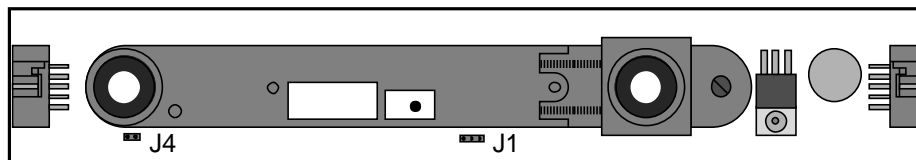

Configuration 2 - SMR: Jumper: J1 “3 Pin” and J4 (Subsequent Slave Module)

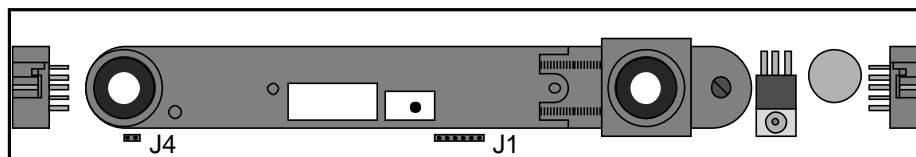

Configuration 1 - SMR: Jumper: J1 “6 Pin” and J4 (Earliest Slave Module)

**MECHANICAL
ADJUSTMENTS –
POSITIONING AND
ANGLING THE
MODULES**

- The positioning of the modules within the aluminum extrusion will be as shown below. The modules will always be positioned so that the transmitter (TX) is at the leading edge of the door. Modules may be flipped around to accommodate handing of doors.

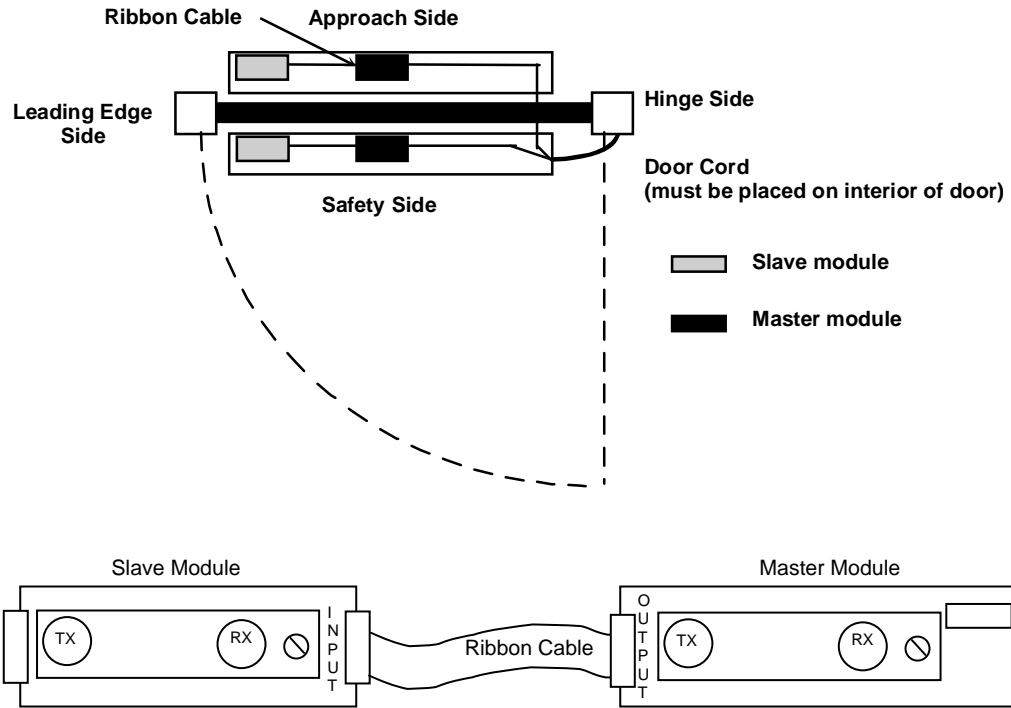

- The angle of each module may be set independently. Use the charts below to help determine the angling. The angles may have to be altered once the units have been powered up and walk-tested.

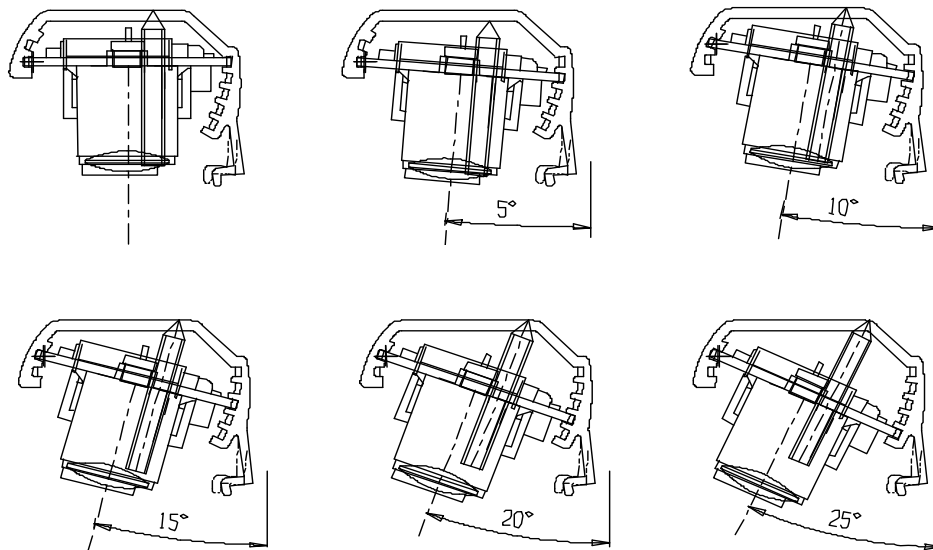

POWER-ON POSITIONING, ANGLING AND ADJUSTING THE MODULES

DEAD ZONE (B) DISTANCE FROM FLOOR	SUPERSCAN ANGLE (C)					
	0°	5°	10°	15°	20°	25°
8"	0	6"	12 ½"	19 ¼"	26"	33 ¼"
12"	0	6"	12"	18"	24 ½"	31 ½"
16"	0	5 ½"	11 ¼"	16 ¾"	23 ¼"	29 ½"
20"	0	5 ¼"	10 ½"	16"	21 ½"	27 ½"

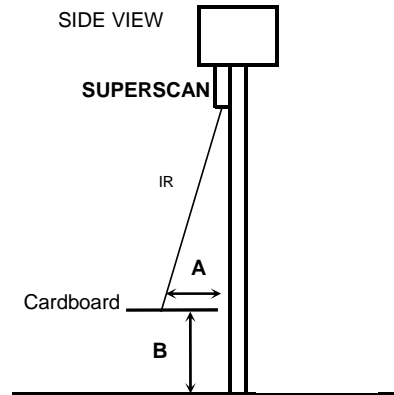
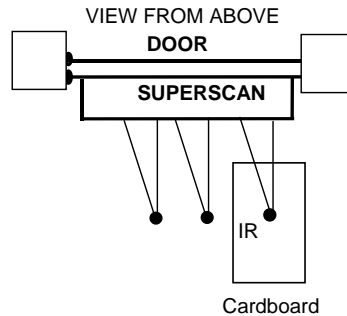

3. The following procedures will be used to adjust each module's detection zone upon power-on, and must be made with the Background Analysis jumper set to "Normal Mode".

- Power the sensors up with 12 to 24 VAC \pm 10% or 12 to 24 VDC \pm 10%. LED status should reflect what was configured for the relay output. Refer to page 8.
- Use a white, gray, or black piece of cardboard about 8" x 11" and hold it as shown in the diagram above.
- Move the cardboard from the floor upward until it is detected. This will determine the height of the dead zone (B distance).
- Measure the height at which the cardboard was detected.
- If this height does not fall between 12" & 16" above the floor or does not meet your requirements, an adjustment must be made to the detection distance.

33

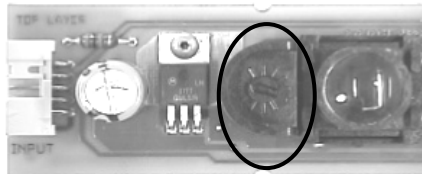

Detection Distance Adjustment

- One notch of the distance adjustment corresponds to approximately 4".
- If Zone B is too high: Turn the distance adjustment clockwise to increase the detection distance and to decrease Zone B.
- If Zone B is too low, turn the distance adjustment counter-clockwise to decrease the detection distance.
- Per current ANSI A156.10, the detection zone must be within 28" of the floor. Ideally, each detector should be adjusted so that detection occurs at 12" to 16" above the floor. Less than 12" of Zone B may result in occasional false triggering of the sensor.
- Once all sensors have been adjusted, activate the door several times and allow it to go through a full cycle each time. Insure that no false triggering is occurring, as would be indicated by the door recycling or stopping by itself at any point of travel.
- Ensure compliance of all applicable safety standards (i.e. ANSI A156.10).
- Install all remaining covers, end caps, screws, etc.

**SMR & NON-SMR
COMPATIBILITY**

When using SMR (self-monitoring ready) and non-SMR modules in the same chain, observe the following rules:

- Mon-SMR Master modules can **NOT** be used with SMR Slave modules.
- All other combinations will work. However, for a system to function as SMR, all modules must be SMR

Identifying an SMR module can be accomplished by looking at the white label on the emitter side of the module. Observe the following to identify each module:

	SMR	NON-SMR
MASTER	EYETECH / MRC	EYETECH / MR
SLAVE	EYETECH / SC	EYETECH / S

For example, a Master module with the marking: EYETECH/MRC would indicate that the module is SMR.

**TROUBLE-
SHOOTING**

PROBLEM	POSSIBLE CAUSE	CORRECTIVE ACTION
SuperScan does not work at all. No LED indications.	Faulty power supply Faulty connections	Power supply must be 12 to 24 VAC \pm 10% or 12 to 24 VDC \pm 10%. Check for this power at terminals 7 & 8 of the affected SuperScan module.
SuperScan output appears to be working opposite of what is expected.	Relay output may be configured improperly.	Refer to page 8 for relay configurations. Be sure to observe the LED indications on the affected modules to help determine status.
Door stops by itself before reaching the full open position.	Safety side SuperScan may be seeing an adjacent wall or rail behind the door near the open position.	Observe the LED status on safety side of door. Find the SuperScan module that is falsely being triggered. Check for: <ul style="list-style-type: none"> <input type="checkbox"/> Proper detection angle <input type="checkbox"/> Detection range adjustment SuperScan may need to be inhibited at a specific point of door travel at the safety side for proper operation. Refer to the terminal connections on page 4.
Activation or safety is being held triggered.	SuperScan detection module may be seeing the floor or unwanted object near door.	Reduce the detection range on the affected module(s). Detection should occur at 12" to 16" above the floor. Refer to page 11.
Erratic detection behavior is occurring throughout the door's opening and closing cycle.	Possible faulty wiring at door transfer location.	Check each wire for continuity with as multi-meter, at the transfer location. Move the wires around during testing to help locate any breaks. Replace faulty wiring as necessary.

ACCESSORIES

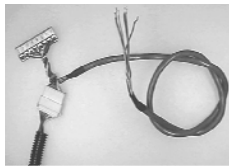

PN: 10SSQD
Quick Disconnect
Cable

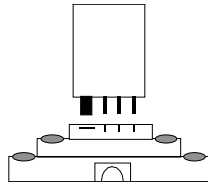

PN: 10REL24V
Isolation Relay

**COMPANY
CONTACT**



Do not leave problems unresolved. If a satisfactory solution cannot be achieved after troubleshooting a problem, please call B.E.A., Inc. If you must wait for the following workday to call B.E.A., leave the door inoperable until satisfactory repairs can be made. Never sacrifice the safe operation of the automatic door or gate for an incomplete solution.

The following numbers can be called 24 hours a day, 7 days a week. For more information, visit www.beainc.com.

West: 1-888-419-2564 **Mid-West: 1-888-308-8843**
South-East: 1-800-407-4545 **North-East: 1-866-836-1863**
US and Canada: 1-866-249-7937 **Canada: 1-866-836-1863**

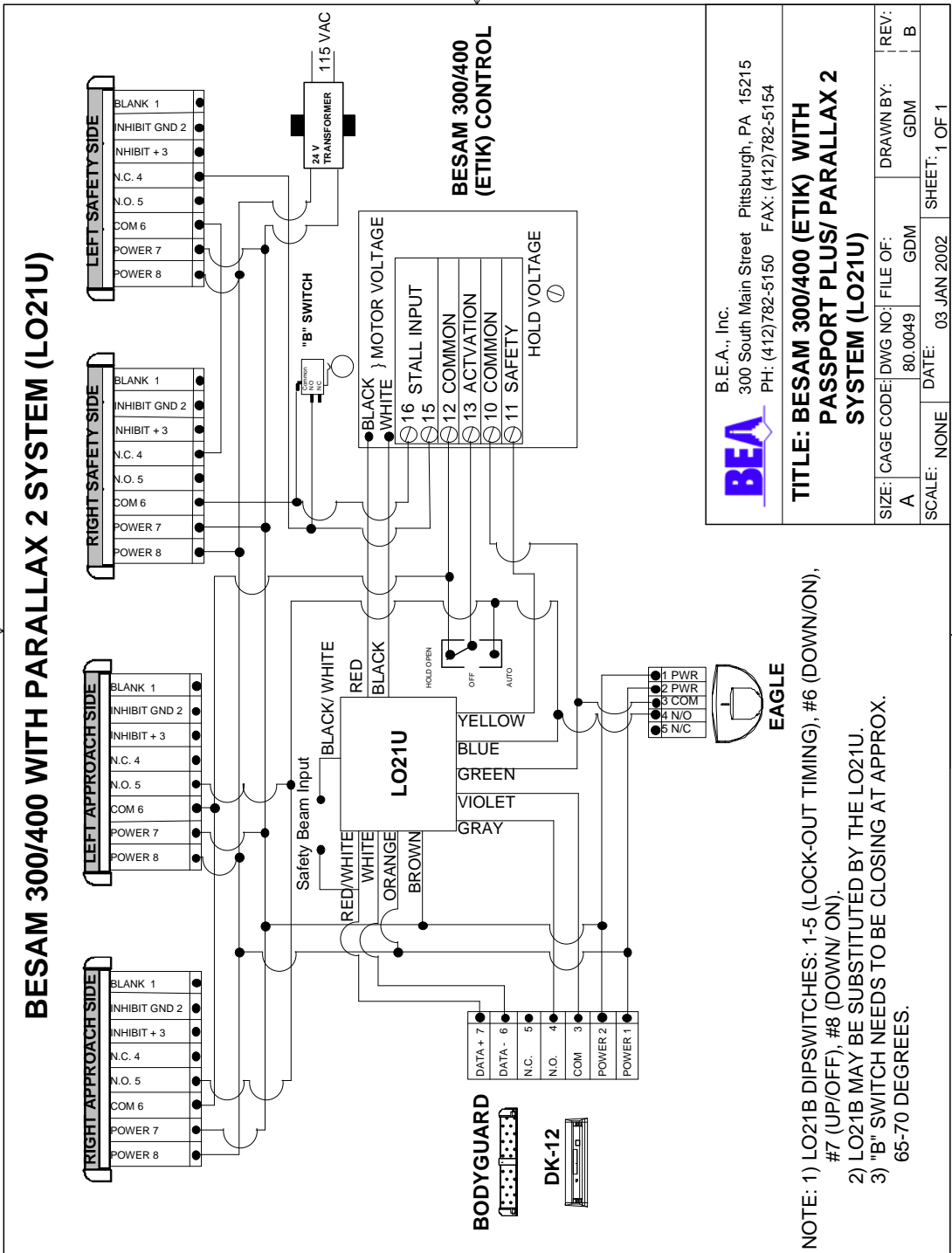

BEA
 B.E.A., Inc.
 300 South Main Street Pittsburgh, PA 15215
 PH: (412)782-5150 FAX: (412)782-5154

TITLE: BESAM 300/400 (ETIK) WITH PASSPORT PLUS/ PARALLAX 2 SYSTEM (LO21U)

SIZE: A	CAGE CODE: 80.0049	FILE OF: GDM	DRAWN BY: GDM	REV: B
SCALE: NONE	DATE: 03 JAN 2002	SHEET: 1 OF 1		

NOTE: 1) LO21B DIPSWITCHES: 1-5 (LOCK-OUT TIMING), #6 (DOWN/ON), #7 (UP/OFF), #8 (DOWN/ ON).
 2) LO21B MAY BE SUBSTITUTED BY THE LO21U.
 3) "B" SWITCH NEEDS TO BE CLOSING AT APPROX. 65-70 DEGREES.

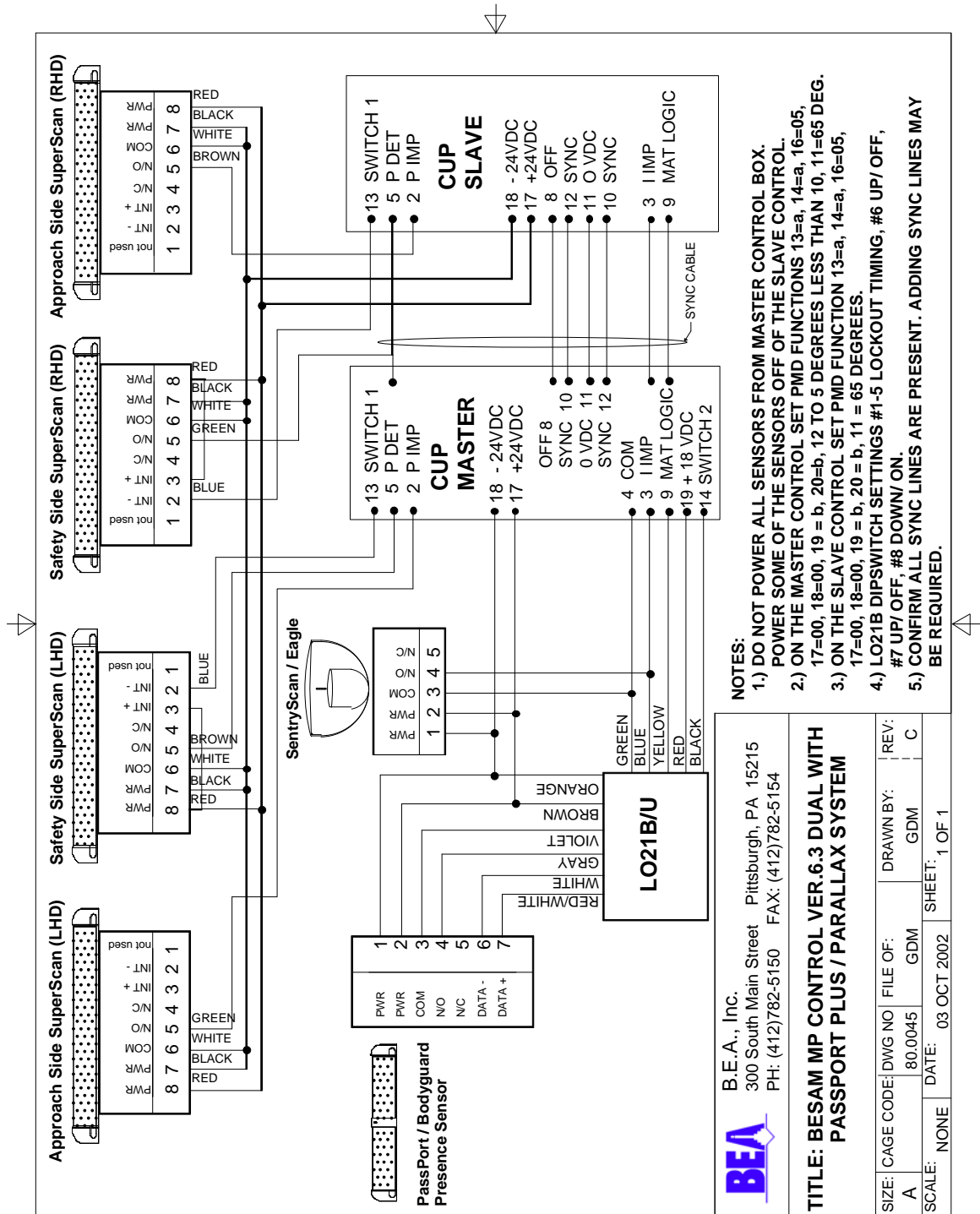

- NOTES:**
- 1.) DO NOT POWER ALL SENSORS FROM MASTER CONTROL BOX. POWER SOME OF THE SENSORS OFF OF THE SLAVE CONTROL.
 - 2.) ON THE MASTER CONTROL SET PMD FUNCTIONS 13=a, 14=a, 16=05, 17=00, 18=00, 19 = b, 20=b, 12 TO 5 DEGREES LESS THAN 10, 11=65 DEG.
 - 3.) ON THE SLAVE CONTROL SET PMD FUNCTION 13=a, 14=a, 16=05, 17=00, 18=00, 19 = b, 20 = b, 11 = 65 DEGREES.
 - 4.) LO21B DIPSWITCH SETTINGS #1-5 LOCKOUT TIMING, #6 UP / OFF, #7 UP / OFF, #8 DOWN / ON.
 - 5.) CONFIRM ALL SYNC LINES ARE PRESENT. ADDING SYNC LINES MAY BE REQUIRED.

BEA
 B.E.A., Inc.
 300 South Main Street Pittsburgh, PA 15215
 PH: (412)782-5150 FAX: (412)782-5154

TITLE: BESAM MP CONTROL VER.6.3 DUAL WITH PASSPORT PLUS / PARALLAX SYSTEM

SIZE: A	CAGE CODE: 80.0045	DWG NO: GDM	FILE OF: GDM	DRAWN BY: GDM	REV: C
SCALE: NONE	DATE: 03 OCT 2002	SHEET: 1 OF 1			

DOROMATIC ASTRO-SWING WITH PARALLAX 2 SYSTEM (LO21)

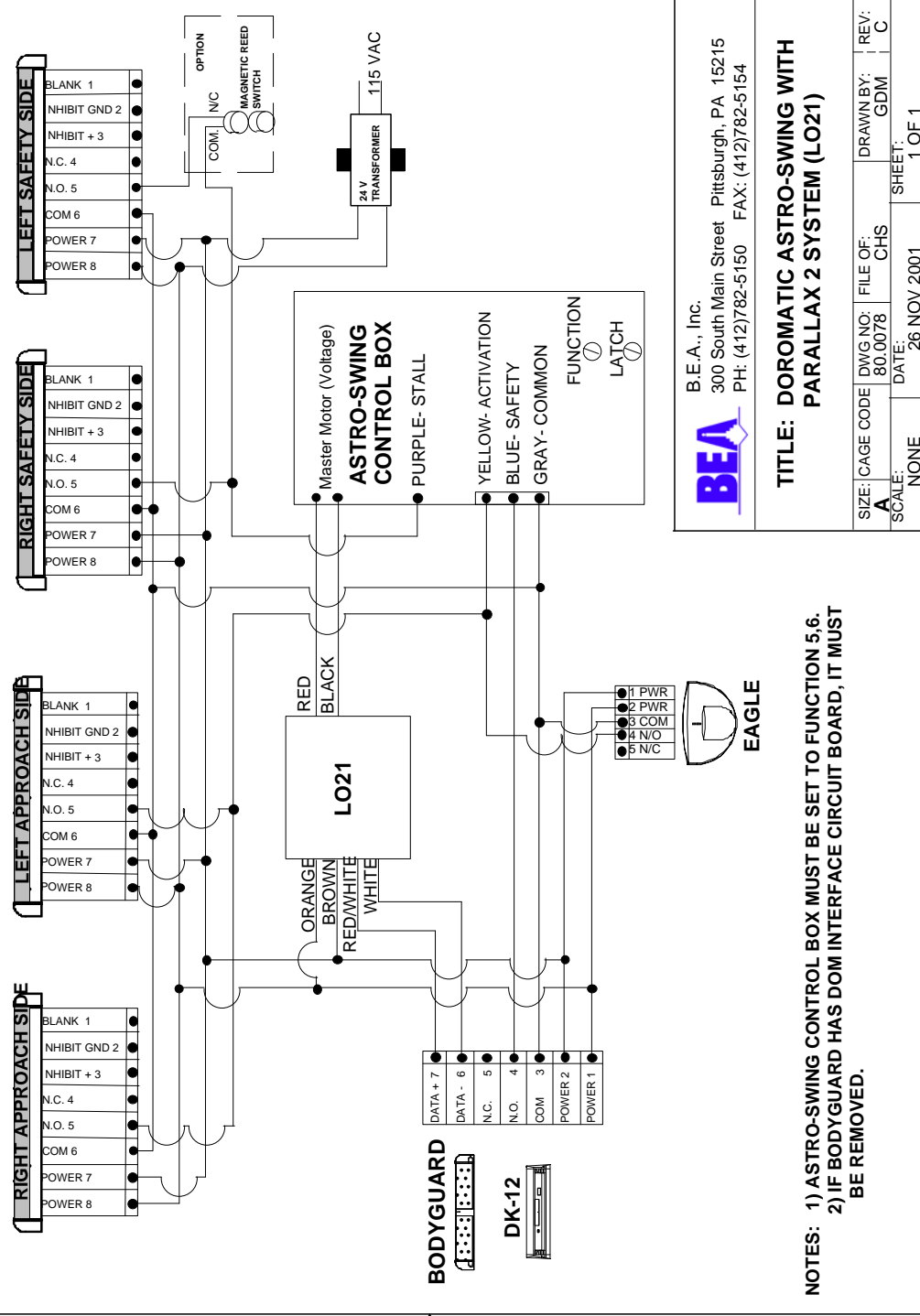

BEA
B.E.A., Inc.
300 South Main Street
Pittsburgh, PA 15215
PH: (412)782-5150 FAX: (412)782-5154

TITLE: DOROMATIC ASTRO-SWING WITH PARALLAX 2 SYSTEM (LO21)

SIZE: A	CAGE CODE: 80.0078	DWG NO: CHS	FILE OF: GDM	REV: C
SCALE: NONE	DATE: 26 NOV 2001	SHEET: 1	OF 1	

NOTES: 1) ASTRO-SWING CONTROL BOX MUST BE SET TO FUNCTION 5,6.
2) IF BODYGUARD HAS DOM INTERFACE CIRCUIT BOARD, IT MUST BE REMOVED.

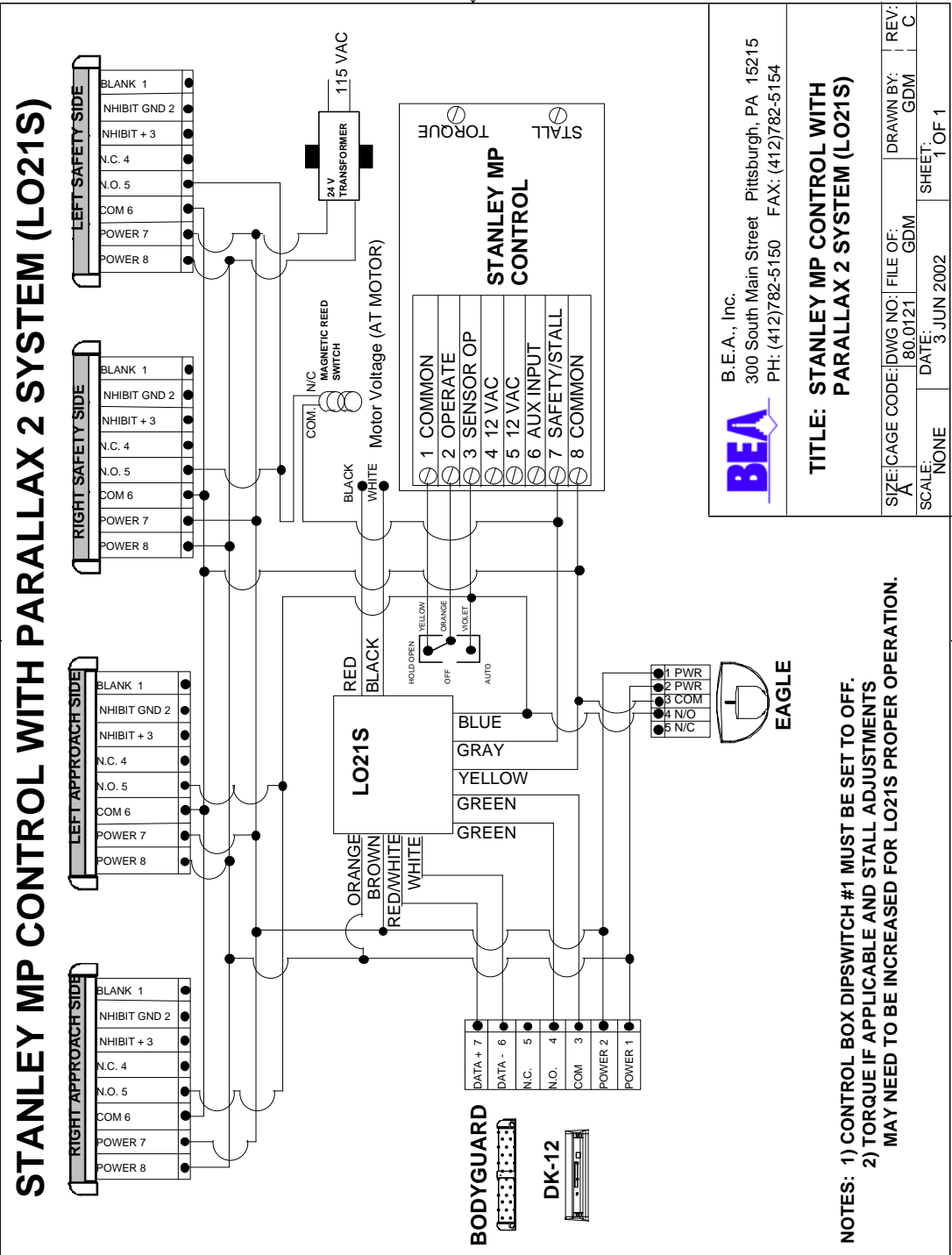

If a wall or a guardrail is detected by the SuperScan in the opening cycle, the SuperScan will need to be inhibited before the detection is allowed to stall the door. For some operators, the back check switch can be used to shut the SuperScan off before the detection occurs. If there is a voltage present across the leads of the back check switch; a relay must be used (as shown below) to supply a dry contact to the SuperScan. When this is performed, the switch is used to toggle voltage on and off at the coil of the relay. The relay, in turn, has 2 sets of isolated outputs: One to trigger the backcheck function at the door control, and the other to open the circuit for the stall function. Thus, when the door reaches the backcheck position and triggers the limit switch, the SuperScan, although in detection, has an interrupted output, thus allowing the door to continue to open through backcheck.

The relay should be energized (voltage applied) when the door is in any position other than backcheck. In this fashion, the configuration lends itself to fail-safe operation. That is, if the relay fails (power loss at relay) the door will operate as if in backcheck.

A 24-volt isolation relay is available from BEA, Inc. with the part number: 10REL24V. Below is a diagram on the wiring of the relay.

